

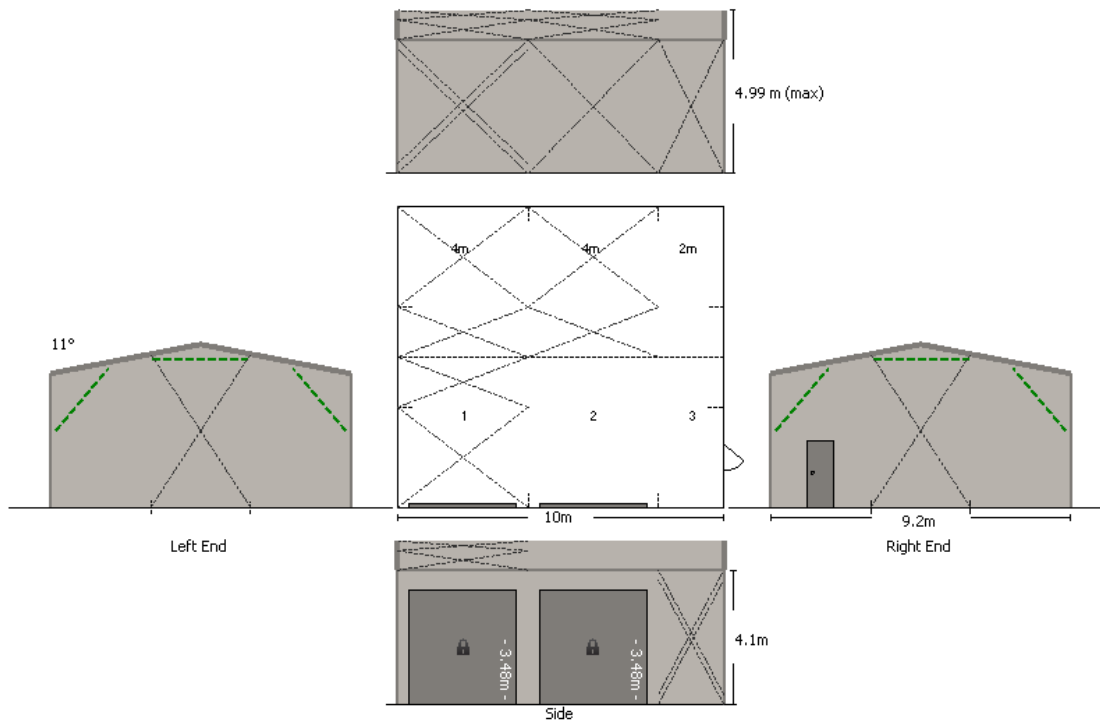

# STEEL BUILDING RECOMMENDED INSTRUCTION MANUAL

Frame First Method



**Project by:**

**Generated on Tuesday, 28 June 2022.**

## Table of Contents

---

1	Disclaimer.....	3
2	General Notes to be read before using this Manual.....	3
3	Glossary of Terms.....	6
4	Diagram of Component Assembly .....	9
5	Guide to the Installation of Temporary Bracing .....	10
6	Components.....	11
7	Guide in using the Instruction Manual .....	17
8	Start of Project .....	17
9	Profile.....	18
10	Foundation.....	18
11	Marking Out the Building.....	19
12	Preassembly of Wall Girts and Roof Purlins.....	20
13	Fitting of Rafters with Apex Bracket .....	20
14	Fitting of Columns with Haunch Bracket .....	23
15	Fitting of Columns with Eave Purlin Bracket.....	24
16	Portal Frame Assembly .....	25
17	Fixing of Apex Brace.....	27
18	Fixing of Knee Brace.....	28
19	Standing the First Portal Frame Assembly.....	30
20	Installation of Endwall Mullion .....	31
21	Standing The Second Portal Frame Assembly.....	33
22	Standing All Portal Frame Assembly .....	33
23	Fitting of C-Eave Purlin.....	34
24	Fixing of Roof Purlins .....	35
25	Fixing of Endwall Girts.....	36
26	Fixing of Sidewall Girts.....	37
27	Fixing of Strap Bracing.....	38
28	Fixing of Fly Bracing.....	40
29	Installation of Sidewall Roller Door Frame .....	41
30	Fixing of Sidewall Sheets.....	43
31	Fixing of Endwall Sheets.....	44
32	Fixing of Gutter .....	45
33	Fixing of Roof Sheets.....	47

34 Fixing of Flashings ..... 49

35 Fixing of Openings..... 52

36 Fixing of Downpipe ..... 53

37 Installation of Personal Access Door..... 54

38 Completion..... 56

## 1 Disclaimer

### Important Disclaimer on this Instruction Manual

- a. This document is to be used and read in conjunction with the plans, drawings and specifications generated by MultiBuild program for this specific job.
- b. Date of Issue – Tuesday, 28 June 2022
- c. Conditions of Use:

By using this guide, you acknowledge and agree that your use is subject to the terms and conditions in this guide. It is your responsibility to ensure that the design you use, the products you have purchased, your site and structural limitations, your building and construction capabilities are appropriate for your needs.
- d. Use of Recommended Genuine Materials:

Structure in this manual should only be constructed using the recommended STRAMIT products or approved third party components. Any warranty can only apply to you if you use the recommended genuine STRAMIT products or approved third party products and Method of Construction recommended in this Manual.
- e. Check of Delivery:

It is important that all materials delivered to site have been checked against the Bill of Materials (BOM) before starting on the project to ensure all components have arrived, are of good quality and ready for installation.
- f. Limitation of Liability  

The information contained in this manual is as far as possible accurate at the date of publication, however, before application in a particular situation, FBHS (AUST) Pty Ltd recommends that you obtain qualified expert advice confirming the suitability of product(s) and information in question for the application proposed as you accept the responsibility and risks. Whilst accepting its legal obligations, be aware however that to the extent permitted by law, FBHS (AUST) Pty Ltd disclaims all liability (including liability for negligence) from all loss and any damage, including damage to goodwill and any loss due to delay resulting directly or indirectly from the use of the information provided in this guide.

## 2 General Notes to be read before using this Manual

Governing Code: National Construction Code Series (Building Code of Australia)

Loading to AS1170 – Parts 0, 1, 2 and 3

### 2.1 Things to do before you commence construction

- a. It is recommended to obtain professional advice to ensure your needs are adequately met.
- b. Check with your local government of any approval or restriction requirements. It is your responsibility to ensure that all approvals required are obtained.

### 2.2 Safety Advice – Important

DISCLAIMER: This is a general safety advice. Refer to relevant state workplace authority website [www.safeworkaustralia.gov.au](http://www.safeworkaustralia.gov.au) for advice on specific items.

NOTE: Do not rely on this guide as exhaustive of all hazards that may exist on a construction site.

Construction hazards must be assessed for risk and controls put in place to reduce the risk identified before commencing the work. This guide is intended to provide an outline of some of the possible risks in erecting a shed or the like but it is not an exhaustive list.

**POSSIBLE RISKS:**

**1. Working at heights**

- a. Try to complete as much of the construction work as possible on the ground
- b. Where a person must work at height, appropriate fall prevention devices e.g. temporary work platforms, scaffolds or guard rails are possible controls you may be able to put in place
- c. If the controls at (b) are not practical then a safety harness or safety net may need to be considered
- d. Any scaffolding, temporary structures or planks should be secured
- e. Any ladder used is fit and appropriate for the task and correctly set up
- f. Appropriate non-slip footwear is worn
- g. Appropriate head protection (hard hat with chin strap) is worn

**2. Personal protective equipment.** Anyone undertaking construction work should wear appropriate:

- a. Eye protection (safety glasses)
- b. Hearing protection (ear plugs, ear muffs)
- c. Hand protection (gloves)
- d. Foot protection (safety shoes / boots)
- e. Head protection (hard hat)
- f. High visibility clothing
- g. Sunscreen

**3. Appropriate tools for the task.** Anyone using tools while undertaking construction should be properly trained in the operation of the tools required.

**4. Manual handling.** These are some basic principles to be observed prior to carrying out a manual handling operation

- a. Ensure that the person lifting the object is aware of its weight and is capable of lifting the object
- b. Make sure the route is clear of obstructions
- c. Make sure there is somewhere to put the load down wherever it is to be moved to
- d. Stand as close to the load as possible and spread your feet to shoulder width
- e. Bend your knees and try to keep the back's natural, upright posture
- f. Grasp the load firmly as close to the body as you can
- g. Use the legs to lift the load in a smooth motion as this offers more leverage reducing the strain on your back
- h. Carry the load close to the body with the elbows tucked into the body
- i. Avoid twisting the body as much as possible by turning your feet to position yourself with the load
- j. Heavy or awkward loads should be moved using a mechanical aid

**5. Noise.** While undertaking construction work, consideration should be given to:

- a. Isolating noisy work and restricting access to noisy areas
  - b. Organising so that the time spent in noisy areas is limited
  - c. Using tools with lower noise emissions
  - d. Use of earplugs or earmuffs
- 6. Working Space.** Due to the size of structures and the component parts, consideration should be given to the need for sufficient working space while undertaking construction.
- 7. Electricity / Power Tools.** In each state or territory, there are specific requirements for management of electrical risks. The information below is an overview of the requirements for electricity safety on residential construction sites.
- a. Flexible (Extension) Cords
    - i. Cords must be used as per the manufacturer's instructions
    - ii. Cords should be located and used in a manner that protects them from damage
  - b. Residual Current Device (RCD's)
    - i. RCD's should be used "in line" with a switchboard
    - ii. If a portable RCD is used, it is recommended that the RCD be connected directly to the switchboard depending on the manufacturer's code rating
    - iii. Portable RCD's should be tested daily before use and then every three months
  - c. Testing and Tagging. Equipment shall be tested and tagged
    - i. When purchased and prior to use (supplier responsible for initial testing)
    - ii. Before a return to use after repair
    - iii. Testing and tagging should be done every three months for portable electrical equipment
  - d. Switchboards
    - i. Must be able to withstand possible damage
    - ii. Be enclosed and have no exposed live parts
    - iii. Be connected to incoming electrical supply by direct method
    - iv. Must be stable when freestanding
- 8. Light.** The construction of a shed or the like should only be undertaken with appropriate lighting. Construction should commence during the day or in an area with sufficient lighting.
- 9. Slips / Trips.**
- a. All access routes are kept clear of materials and debris
  - b. All leads kept clear of ground or covered
  - c. All surfaces used for access kept dry in a good condition
- 10. Engaging a Contractor in Constructing a Shed.** The contractor undertaking the construction of a shed for the customer shall have appropriate systems in place to meet the health and safety obligations set out in state and territory legislation.

Check with your local workplace health and safety authority for measures required to be put in place prior to and during construction. It is the responsibility of the builder, erector and or installer to ensure all safety work practices are in place. The safety of the whole site has to be maintained at all times. Due consideration has to be given to site safety in regard to locations of bracing and pegs.

### 2.3 Maintenance Guide

Refer to Stramit website for maintenance guide and requirements. Consult the guide for maintenance, handling and other technical information you may require.

### 2.4 Descriptions of Products

All specifications, drawings, data and dimensions in this manual are approximations only. Refer to the Engineering Plans and Specifications with this manual.

## 3 Glossary of Terms

**Apex Brace** – A C-Purlin component attached to each side of the rafter web to act as brace.

**Apex Bracket (pressed)** – A pressed bracket joining the top end of 2 rafters attached to rafter webs to form the roof apex.

**Barge Capping** - A flashing attached to the top of end wall cladding and over the roof sheets to cover the gap between the wall and roof cladding.

**Bolted Frame** – A portal frame with Bolt type fasteners.

**Bolts** – A fastener type used for bolted frame application

**C- Eave Purlin** – A C-Purlin acting as support to top of wall sheeting and bottom of roof sheeting on the lower or higher end of the structure as applicable.

**Column** – A C-Purlin component laid vertically and attached to C-Purlin Rafter with a haunch bracket.

**Corner Flashing** – A flashing type to cover the gap of two intersecting sheeting or structural members for weather protection.

**Cover Flashing** – A flashing type to cover the open side of a C-Purlin Eave Trimmer, Rafter or Column.

**Eave Purlin Bracket** – A folded U-shaped bracket attached to lip and web of a C-Purlin Column to support the C-Eave Purlin. For double application, the bracket is attached to lip of each Column.

**Eave Trimmer** – A C-Purlin component attached to the end of Rafter with eave trimmer bracket for roof sheeting and gutter attachment.

#### **Eave Trimmer Flashing**

A flashing type to cover the C-Eave Trimmer.

**End Wall Girt** – A tophat or Z-Purlin attached to Endwall Girt Bracket. Endwall girt is flushed to *the outside face of the endwall column*.

**End Wall Girt Bracket** – An angle bracket attached to the flange of a C-Purlin End Column to support endwall girt.

**End Wall Mullion** – A C-Purlin Column rotated 90 degree to the End Rafter and is offset from the slab edge by the width of the endwall girt.

**Fly Brace** – A metal strap brace attached to the flange of a C-Purlin Column/Rafter, wraps around the Column/Rafter and attached to the lip/flange of a wall girt/purlin.

**Gable Angle Trim** – An angle bracket attached to purlin flange to support the top end of wall cladding.

**Gable Eave Trimmer Bracket** – A bracket attached to the low end of the rafter to support the C-Eave Trimmer

**General Purpose Bracket** – A pre-punched angle bracket for various applications.

**Gutter** – A rollformed rainwater product attached to the lower end of the roof for water drainage.

**Gutter Support Flashing**– A flashing type attached to purlin flange and to lip of C-Eave Trimmer to support the gutter.

**Haunch Bracket (Pressed)** – A pressed bracket attached to top of a C-Purlin Column and to base of a C-Purlin Rafter to form part of a portal frame.

**Hold Down Bracket** – A folded U-shaped bracket attached to the base of a C-Purlin Column flange on both sides and embedded to concrete.

**Knee Brace** – A C-Purlin member attached to a C-Purlin Column and a C-Purlin Rafter to act as a brace.

#### **Leanto Mono Flashing - Bottom**

A flashing type, part one of two, attached to bottom of purlin to cover the ends of purlin on the high end of Leanto roof.

#### **Leanto Mono Flashing – Top**

A flashing type, part two of two, attached to roof sheeting through to top of purlin and to the bottom flashing to cover the ends of purlin on the high end of Leanto roof.

#### **Mono Angle Trim**

An angle bracket attached to Purlin to support the top end of wall cladding on the high end of the roof.

**Mono Eave Trimmer Bracket** – A bracket attached to the high end of the rafter to support the Eave Trimmer.

**Mullion Fixing Angle** – An angle bracket with various usages such as attachment of the C-End mullion to Rafter or attachment of Leanto Rafter to Main Column.

**Personal Access Door Jamb** – A folded bracket attached to either the next wall girt above the door opening or the C-Eave Purlin. The 2 types are with rebate or without a rebate.

**Portal Frame** – A frame which consists of a C-Purlin Column and a C-Purlin Rafter attached with Haunch bracket and Apex bracket to form a portal frame.

**Rafter** – A C-Purlin attached to the top of a C-Purlin Column with a Haunch Bracket.

**Ridge Capping** – A flashing to cover the gap where two roof sheetings meet at ridge point.



**Roller Door Jamb (side wall)** – A folded bracket attached to either the wall girt above the door opening or the C-Eave Purlin or Tophat Eave Purlin.

**Roller Door Header** – A C-Purlin placed above the roller door opening between the door jambs.

**Roof Purlin** – A Z-Purlin or a Tophat directly attached to the flange of a Rafter with tek screw or bolt.

**Roof Sheeting** – A metal sheeting profile attached to roof purlins for weather protection.

**Sidewall Girt** – A Z-Purlin or Tophat directly attached to flange of a C-Purlin Column.

**Wall Cladding** – A metal sheeting profile attached to wall girts to cover the walls of the building.

# 4 Diagram of Component Assembly

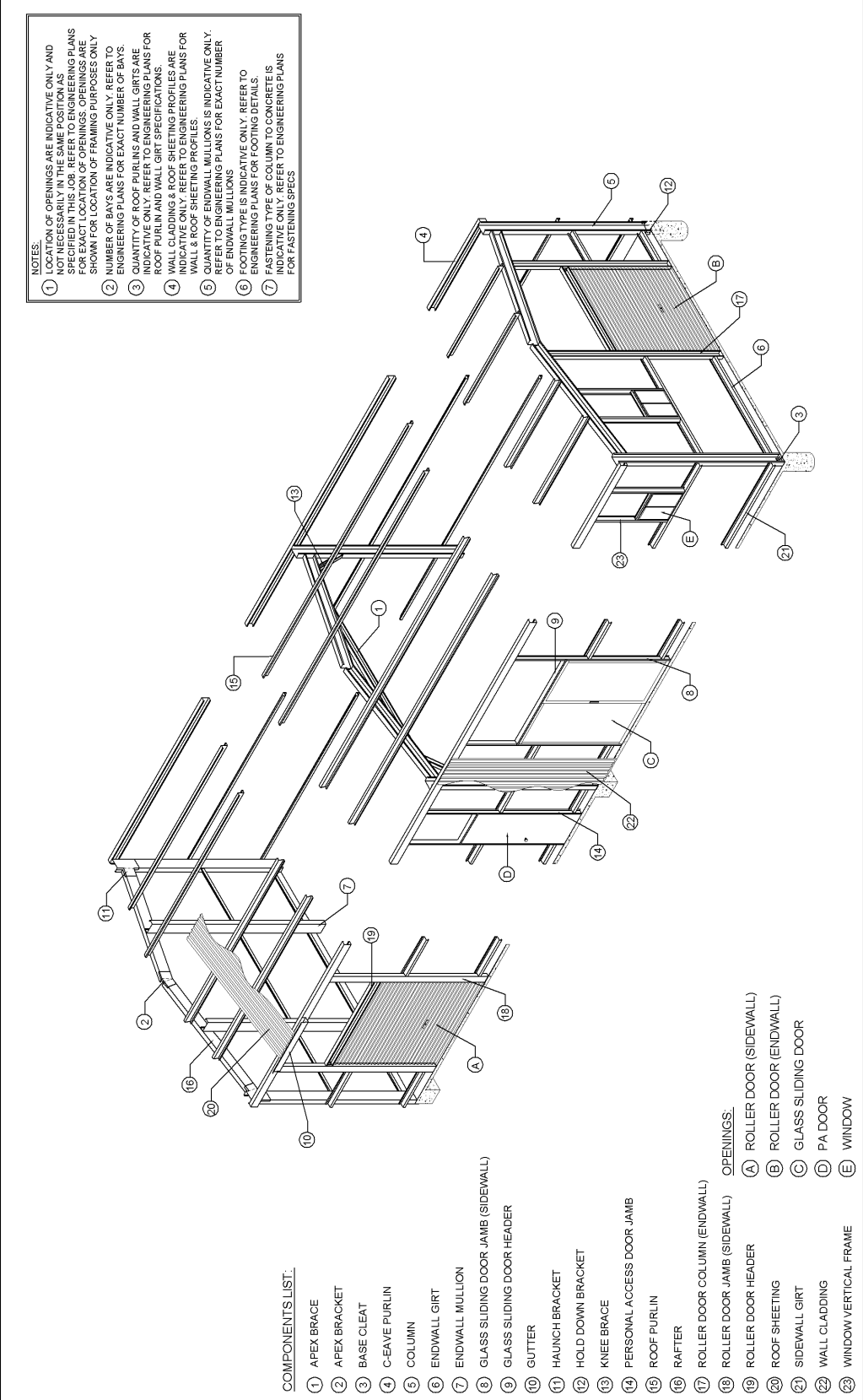

# 5 Guide to the Installation of Temporary Bracing

## GUIDE TO THE INSTALLATION OF TEMPORARY BRACING

(REFER TO INSTALLATION GUIDE MANUAL FOR THE TWO METHODS OF CONSTRUCTION)

**NOTES:**  
 BRACING MATERIALS - THE SHED ERECTOR TO SUPPLY SPECIFIC BRACING SUITABLE RIGID MEMBERS CAPABLE OF TENSION AND COMPRESSION OR OPPOSING CHAINS OR OPPOSING, LOAD RATED RATCHET STRAPS TO BE USED. RIGID BRACING AS SHOWN ON DIAGRAM. ROPE BRACING SUITABLE ONLY FOR SMALLER STRUCTURES IN IDEAL CONDITIONS.

**BRACING LOCATION** - TEMPORARY BRACING TO BE ERRECTED AS CLOSE TO 45 DEGREE ANGLE AND FIXED TO THE TOP OF THE COLUMN OR MULLION TO ACHIEVE THE OPTIMUM EFFECTIVENESS. IF THERE IS NOT ENOUGH SPACE FOR A 45 DEGREE ANGLE, THEN 20 DEGREE ANGLE IS TO BE THE MINIMUM ANGLE ALLOWED (REFER TO DIAGRAM). RIGID TEMPORARY BRACING MEMBERS TO BE BOLTED TO HEAVY ANGLE PEGS HAMMERED INTO THE GROUND OR TO A BRACKET, MASONRY ANCHORED TO THE SLAB.

**BRACING REMOVAL** - TEMPORARY BRACING TO REMAIN IN PLACE UNTIL CLADDING IS FULLY INSTALLED WHERE POSSIBLE. IN NO CASE SHOULD TEMPORARY BRACING BE REMOVED UNTIL ALL PURLINS, GIRTS (AND PERMANENT CROSS BRACING WHERE USED) ARE FIXED.

**SITE SAFETY** - DUE CONSIDERATION TO BE GIVEN TO SITE SAFETY IN REGARD TO LOCATIONS OF BRACING AND PEGS.

**GUIDE APPLICATION** - TEMPORARY BRACING AS DESCRIBED IS A MINIMUM REQUIREMENT FOR AN AVERAGE, STANDARD SITE CONDITION. PROVIDE ADDITIONAL BRACING FOR MORE SEVERE AND/OR HIGH EXPOSURE SITE CONDITIONS. ADDITIONAL BRACING TO BE USED AS AND WHERE NECESSARY TO ENSURE THAT ENTIRE FRAME IS RIGID THROUGHOUT CONSTRUCTION. RESPONSIBILITY FOR BRACING STABILITY OF STRUCTURE REMAINS WITH THE BUILDER.

**TILT UP METHOD**  
 FOR STRUCTURES UNDER 9M SPAN, LESS THAN 3M HIGH AND LESS THAN 12M LONG

- ASSEMBLE THE FIRST SIDEWALL FRAME (COMPLETE WITH WALL SHEETING, BRACING AND GUTTER) ON THE GROUND AND LIFT ASSEMBLED SIDEWALL FRAME INTO POSITION. FIX OFF TEMPORARY SIDE BRACING TO EACH END (REFER TO DIAGRAM). FIX BASE CLEATS.
- ASSEMBLE THE SECOND SIDEWALL FRAME AS PER FIRST SIDEWALL FRAME. LIFT INTO POSITION. FIX OFF TEMPORARY WALL BRACING TO EACH END (REFER TO DIAGRAM)
- FIX GABLE END BATTERS TO COLUMNS TO THE WALLS. PROP APEX UNTIL ENDWALL MULLION AND APEX TEMPORARY BRACE ARE TRUED OFF. IF NO MULLION IS REQUIRED THEN PROP AND APEX TEMPORARY BRACE ARE TRUED OFF.
- INSTALL REMAINING BATTERS. AS EACH BATTER PAIR IS INSTALLED, AT LEAST ONE PURLIN PER 3M OF BATTER LENGTH IS TO BE INSTALLED TO SECURE BATTERS.
- INSTALL REMAINING PURLINS.
- INSTALL KNEE AND APEX BRACES IF AND WHERE APPLICABLE.
- REPEAT FOR LEANTOS.

**FRAME FIRST METHOD** - APEX AND KNEE BRACES ARE NOT REQUIRED WITH 3RD LD BRACKETS. FOR STRUCTURES OVER 9M SPAN, GREATER THAN 3M HIGH AND GREATER THAN 12M LONG

- ASSEMBLE PORTAL FRAMES ON THE GROUND (WITH KNEE AND APEX BRACES IF AND WHERE APPLICABLE). LIFT THE FIRST PORTAL FRAME ASSEMBLY INTO POSITION.
- FIX OFF TEMPORARY END BRACING (REFER TO DIAGRAM). FIX BASE CLEATS.
- IF NO MULLION IS REQUIRED THEN PROP AND BRACE APEX UNTIL CLADDING IS COMPLETE.
- THE SECOND PORTAL FRAME ASSEMBLY TO BE LIFTED INTO POSITION. FIX EAVE PURLINS AND AT LEAST ONE PURLIN PER 3M OF BATTER TO SECURE FRAME ASSEMBLY.
- FIX BASE CLEATS. FIX TEMPORARY SIDEWALL BRACING.
- STAND REMAINING PORTAL FRAME ASSEMBLY AS PER STEP C. FINISH TEMPORARY SIDE WALL BRACING TO EVERY SECOND BAY. BRACE OTHER END PORTAL FRAME AS PER FIRST PORTAL FRAME.
- INSTALL REMAINING PURLINS AND GIRTS.
- REPEAT FOR LEANTOS.

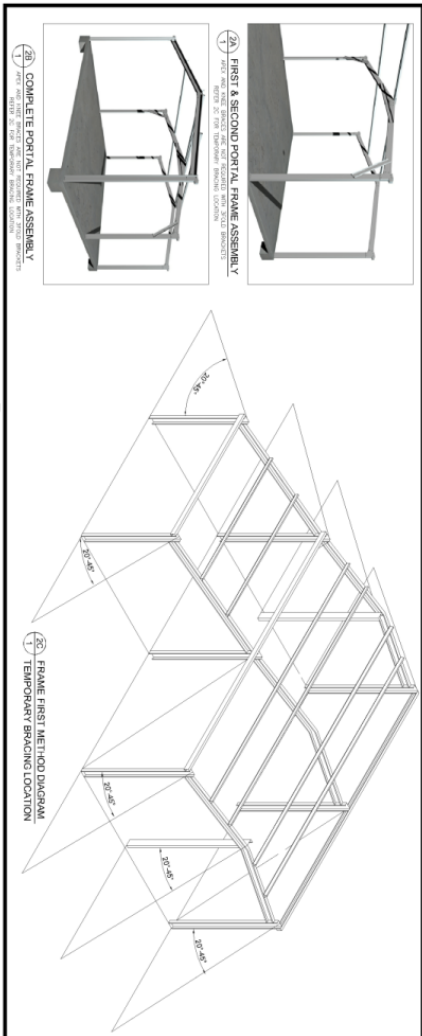
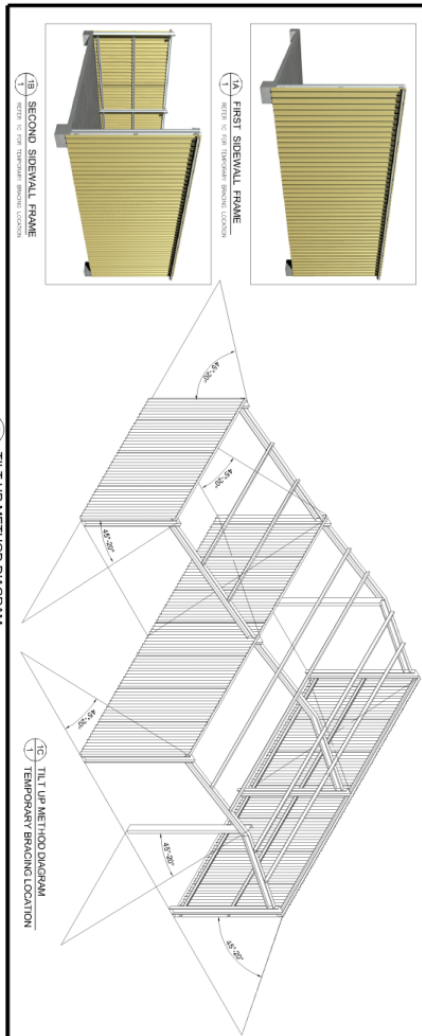

## 6 Components

### Apex Brace

A C-Purlin member that attaches to each side of the rafter to act as brace.

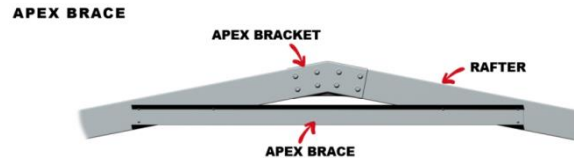

### Apex Bracket (pressed)

A pressed bracket that wraps around the outer face webs and flanges of a rafter which joins the two rafters to form the roof apex.



### Barge Capping

A flashing that attaches to the gable end wall cladding over the roof sheets to cover the gap between the top of the endwall cladding and the roof sheeting to a neat finish.



### Bolted Frame

A portal frame with structural frame bolt fasteners type.

### Bolts

A frame fastener type for bolted frame application.



### C- Eave Purlin

A C-Eave Purlin to support top of wall sheeting and lower end of roof sheeting of a Gable Roof type structure and on both lower and upper sides of a Monopitch type structure.

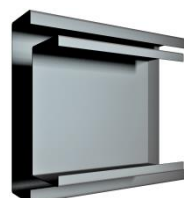

### Column

A C-Purlin vertical member to support C-Purlin rafter.



**Corner Flashing**

A flashing type to cover the gap between two intersecting sheeting or structural members for weather protection.

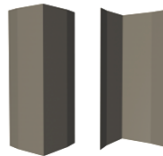

**Eave Purlin Bracket**

A folded U-shaped bracket that attaches to inside web of a C-Purlin Eave Purlin to lip and outer web of C-Purlin column.

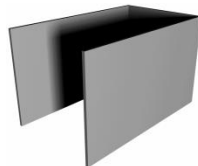

**End Wall Girt**

A Z-Purlin or tophat that attaches to the flange of a column with an endwall girt bracket. Endwall girt is flushed to the outside face of the endwall column.

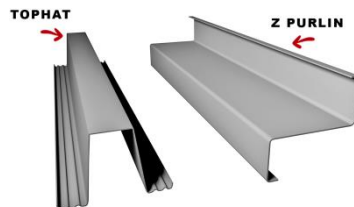

**End Wall Girt Bracket**

An angle bracket that attaches to the flange of a column to either a Z-Purlin or to a tophat endwall girt.



**End Wall Mullion**

A column rotated 90 degree and is offset by the width of an endwall girt.

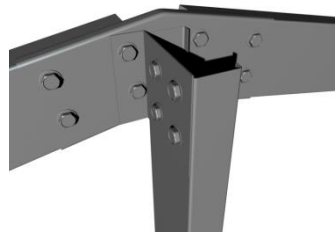

### Fly Brace

A metal strap brace to attach to the outer web of column and or rafter to either a tophat or Z –Purlin girt and or purlin.

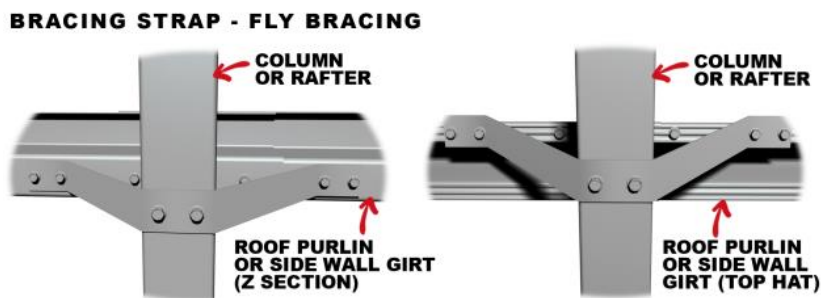

### Gutter

A rollformed rainwater product that attaches at the lower end of the roof for water drainage.

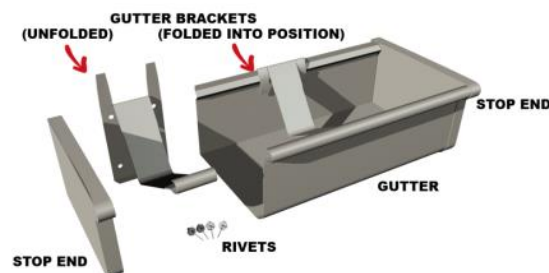

### Haunch Bracket (Pressed)

A pressed bracket that attaches to top of a column and to base of a rafter. Haunch bracket is attached to the outside web face of both column and rafter.



### Hold Down Bracket

A folded U-shaped bracket that attaches to the base of column flanges on both sides and embedded to concrete.



SINGLE HOLD DOWN BRACKET DOUBLE HOLD DOWN BRACKET

### Knee Brace

A C-Purlin member that attaches to a column and a rafter to act as a brace.

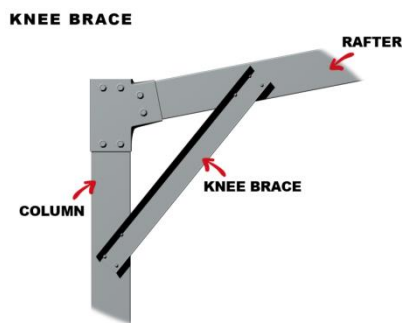

**Mullion Fixing Angle** – It is an angle bracket that has multiple uses. It can be for an attachment of the end mullion to the rafter or attachment of a leanto rafter to the flange of a main column.

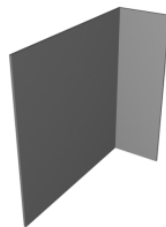

### Personal Access Door Jamb

A folded bracket that attaches to either the next wall girt above the door or the C- Eave Purlin. The bracket to be notched out and the flanges attach to sides of either the girt or eave purlin. It comes either with or without a rebate.

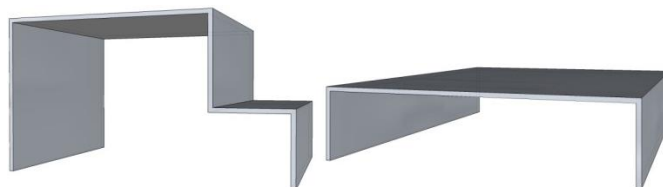

### Portal Frame

A frame which consists of a column and a rafter assembled with haunch and apex brackets to form a portal frame. Knee and Apex braces are optional.

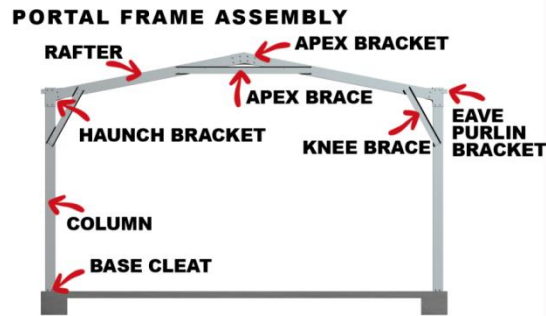

**Rafter**

A C-Purlin member to support the roof purlin fixed to the top of a column with a haunch bracket and fixed to the other rafter with an apex bracket.



**Ridge Capping**

A flashing to cover the gap where two roof sheetings meet at ridge point.



**Roller Door Jamb (side wall)**

A folded bracket that attaches to either the next wall girt above the door opening or the C-Eave Purlin or tophat eave purlin.

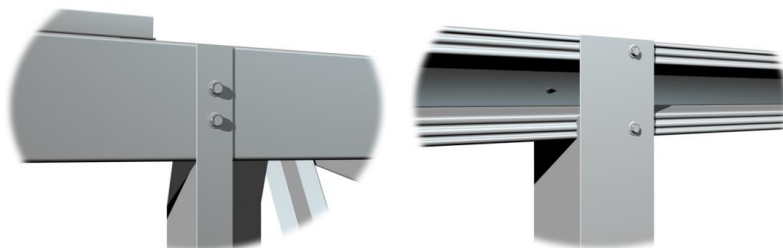

**Roller Door Header**

A C-Purlin member above the roller door opening that attaches to the flange of the roller door column to inside web of the header with an angle bracket.





**Roof Purlin**

A Z-Purlin member or a tophat that directly attaches to the top flange of a C-Purlin rafter with tek screws.

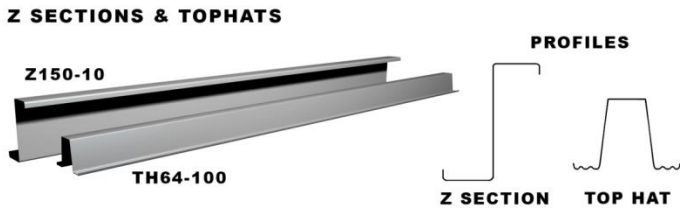

**Roof Sheeting**

A metal sheeting profile to cover the roof of the building and attaches to the roof purlins.

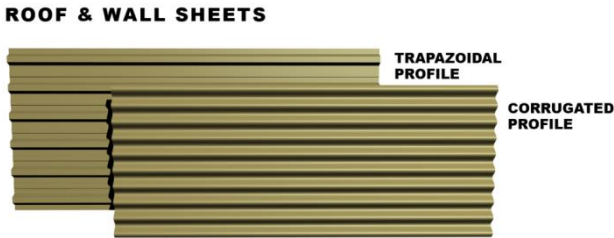

**Sidewall Girt**

A Z-Purlin or tophat that directly attaches to the flange of a C-Purlin frame column.

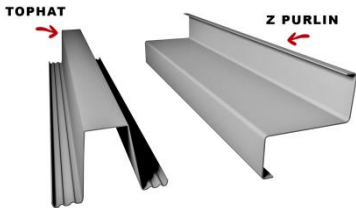

**Wall Cladding**

A metal sheeting profile to cover the walls of the building and attaches to the wall girts.

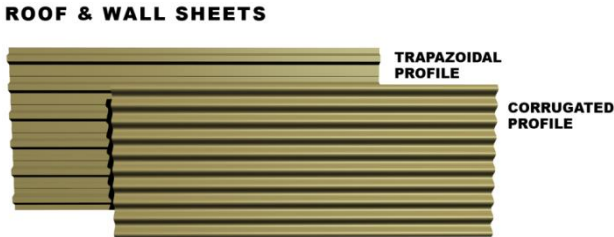

## 7 Guide in using the Instruction Manual

**You must read these instructions carefully before starting on the project.**

### Recommended Tools

- a) Ladder
- b) Plank
- c) Saw Horses
- d) Angle Grinder
- e) Electric Lead
- f) Spirit Level
- g) Drill and Drill Bits for concrete/masonry and steel
- h) Pop Rivet Gun
- i) Safety Glasses
- j) Gloves
- k) Assortment of Hand Tools such as impact driver/tek gun (electrical), power box, nibbler, clamps, hammer and all other tools you require
- l) Socket Set

### Check against components delivered and the Bill of Materials.

It is important to check the delivered components against the Bill of Materials. If there is discrepancy with what is received and the BOM, please contact the distributor where you purchased immediately prior to the commencement of the project.

### Site Preparation

Prepare the work area for the construction. Clear the work area of obstacles and debris to be a safe place to work in.

## 8 Start of Project

**OTHER TEMPORARY BRACING REQUIREMENTS ARE OMITTED IN ALL THE IMAGES FOR CLARITY. REFER TO "GUIDE TO THE INSTALLATION OF TEMPORARY BRACING".**

The information in this guide is suitable only for: **'306 Old Clare Road Ayr, 4807'** with the following:

Project Design Criteria	
Wind Region	C
Topography	1
Shielding Factor	1
Terrain Category	2
Importance Level	2

**Gable Roof structure** for a 9.2m span x 10m long x 4.1m high enclosed garage with 1 personal access door on endwall, 2 roller doors on sidewall.

IT IS IMPERATIVE TO REFER TO THE ENGINEERING PLANS SUPPLIED WITH THIS MANUAL FOR SPECIFICATIONS AND DETAILS TO ALL THE CHAPTERS INCLUDED IN THIS MANUAL.

## 9 Profile

A profile is a set-out of a concrete slab. Build the profile on each corner of the building allowing for enough space to set out the corners of the concrete slab. Nail strings on 4 sides for set-out of the edges of the concrete slab. The diagonal measurements of the strings from each corner must be equal. Ensure that the strings are square by measuring 300mm on the span side and 400mm on the length side. The measurement of the end points of these 2 measurements should be 500mm. The image shows 3, 4 and 5 to represent the measurements correspondingly. The 4 string lines are equivalent to the slab edges. The intersection of 2 strings is the corner of the slab. The concrete slab dimensions should be the exact dimensions of the building.

The diagonal measurement of the slab is equal to 13.588 meters for the Main Building.

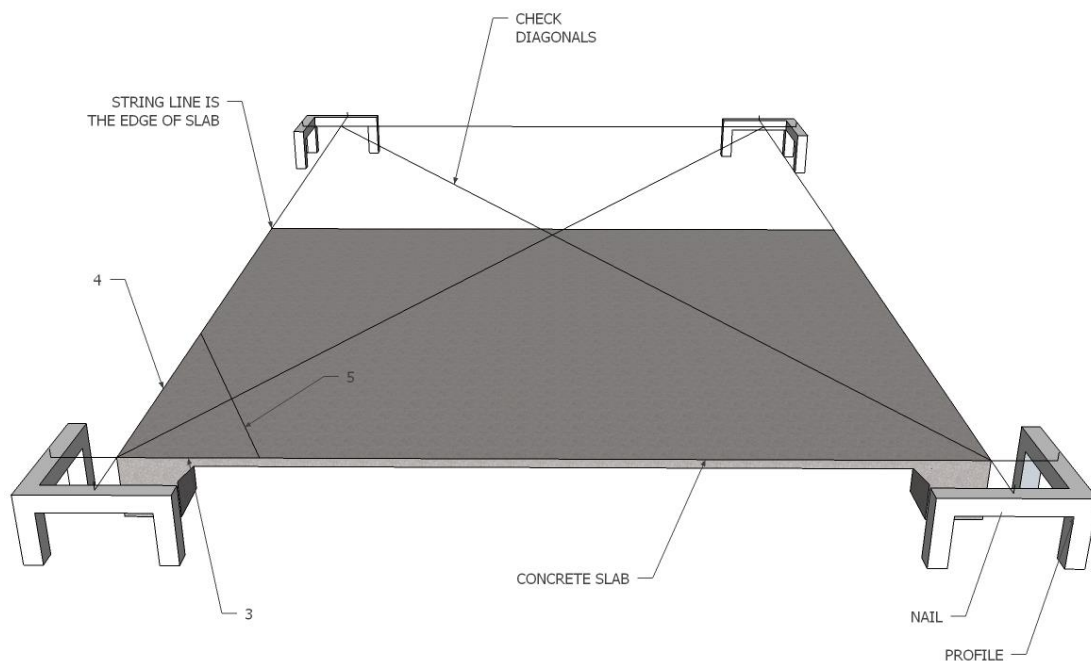

## 10 Foundation

The concrete slab dimensions should be the exact dimensions of the building. Building dimensions are taken from outside to outside of the wall girts to allow the wall cladding to go past the slab by 25mm. It is very important that the 2 diagonal measurements of the concrete slab be equal, square and level. The concrete slab will be supported by either a block pad or bored or strip footing as required. If slab is present, footings are not centered under the columns.

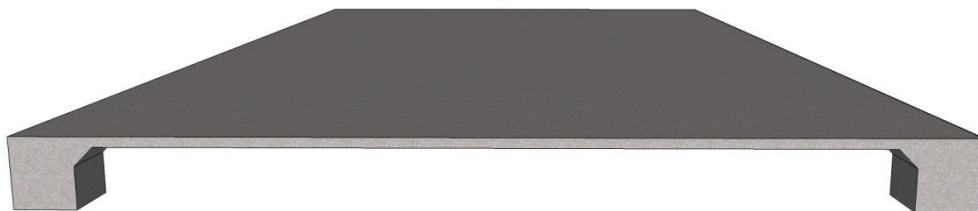

## 11 Marking Out the Building

Measure the width and the length of the slab and ensure that it is equivalent to the size of the building as per Engineering Plans. Measure the 2 diagonals and ensure that the dimensions are equal, level and square.

Mark out (chalk line) the inside face of the C-Purlin column from the edge of the slab along one side of the length of the building. This distance is equal to the web size of the C-Purlin column and the width of the girt and is referred to as "Frame Dist". Repeat the procedure to the other side along the length of the building.

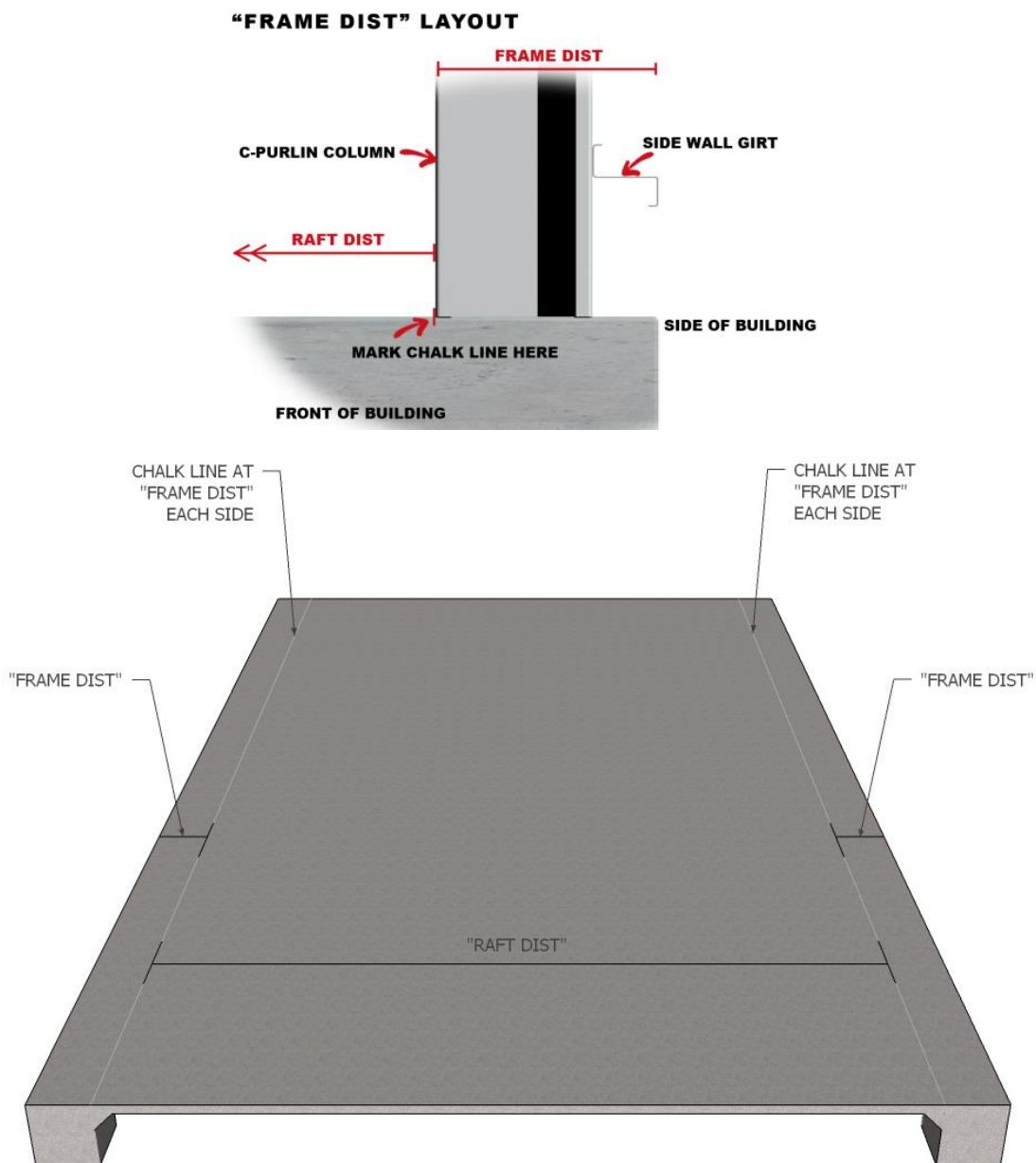

The distance between the inside face of the C-Purlin columns is referred to as "Raft Dist". This distance is equal to the span of the building minus 2 x "Frame Dist". The "Raft Dist" is equal to the measurement of an assembled rafter on the slab from RAFT POINT 1 to RAFT POINT 2. This will be discussed more in the "Fitting of Rafters with Apex Bracket" Chapter.

NOTE: For the set-out of the C-Purlin column and the fastening type to the concrete slab, refer to the Bolt Layout Plan or Hold Down Bracket Layout Plan (as required) on the Engineering plans.

The overall length of the building is from outside face of the C-Purlin column on each endwall.

#### Hold down Bracket (HDB) - Slab Application

If Hold-Down Bracket (HDB) is the required Base Connection for Slab Application, position the HDB bracket in the correct location before slab or footing is poured. Attachment of Column to HDB bracket will be discussed in “Standing the First Portal Assembly” Chapter.

## 12 Preassembly of Wall Girts and Roof Purlins

Lay out sidewall girts and purlins on the slab. Join and lap two (2) girts with tek screws to suit the length of the building as specified on the Engineering Plans. For ease of handling, it is recommended that joining should be no more than 2 multiples at a time. Refer to the Engineering Plans for tek screw specifications and details. Repeat the same procedure for the purlins.

**NOTE: The overlap widths of girts and purlins may not necessarily be the same so it is important to refer to the Engineering Plans.**

**NOTE: The number of tek screws may not necessarily be the same for girts and purlins so it is important to refer to the Engineering Plans.**

Mark girts with a permanent marker the Intermediate Portal Frame positions as per Engineering Plans. Repeat the same procedure for the purlins. Move aside for later use.

### SIDE WALL GIRTS & ROOF PURLINS

#### OVERLAP CONNECTION DETAIL

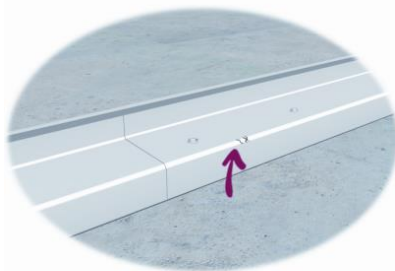

**MEASURE & MARK POSITION OF INTERMEDIATE PORTAL FRAMES**

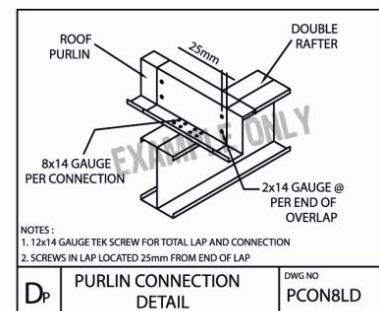
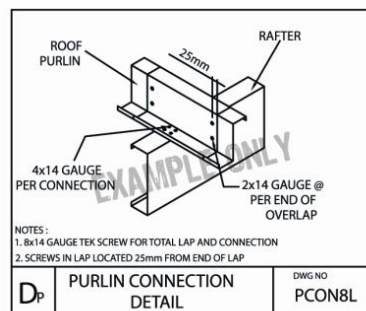

## 13 Fitting of Rafters with Apex Bracket

Layout rafters and apex brackets on the slab. Ensure that the correct end of the rafter is at the top. This can be achieved by measuring the punching of the apex bracket against the punching on the rafter. Start the rafter assembly to the first set of rafters and apex bracket. Lay the first 2 rafters flat on the slab, web facing up at the approximate roof pitch. Ensure that the rafters meet at the lower apex. Attach the apex bracket to the top end of the rafter forming an apex. Keep the apex bracket temporarily in place with 6 frame tek screws, 1 at the bottom of each rafter. Measure RAFT POINT 1

to RAFT POINT 2 and adjust until measurement equals RAFT DIST. Refer to “Marking Out the Building” Chapter for RAFT DIST criteria. Bolt the apex bracket securely into position. Repeat procedure to the rest of the rafters. Stand rafter assembly side by side, measure and mark on the rafter the position of purlins based on the spacing specified on the engineering plans. Move aside for later use.

NOTE: Due to the **configuration** of the standard haunch brackets being used, the “RAFT-DIST” criteria is NOT applicable to all roof pitches and rafter frame size. Refer to table below.

RAFTER SIZE	ROOF PITCH					
	5°	11°	15°	22°	30°	45°
	"RAFT-DIST" CRITERIA					
C100	A	A	A	A	N	N
C150	A	A	A	A	N	N
C200	A	A	A	A	N	N
C250	A	A	A	A	N	N
C300	A	A	A	A	N	N
C400	A	A <td A	A	N	N	

**NOTES:**

A - APPLICABLE

N - NOT APPLICABLE

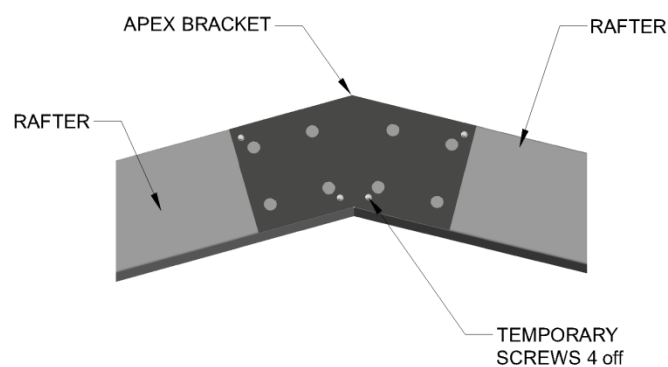

FITTING OF RAFTERS WITH APEX BRACKET

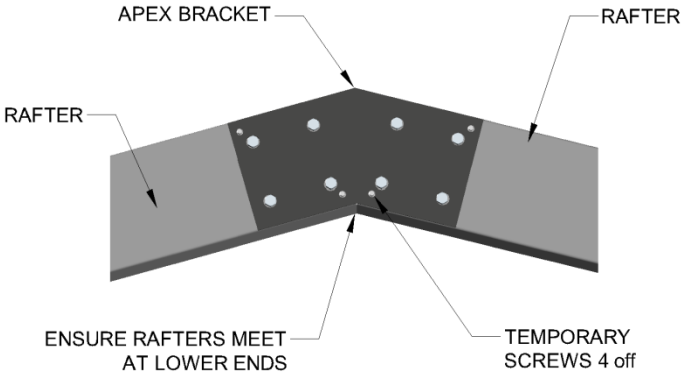
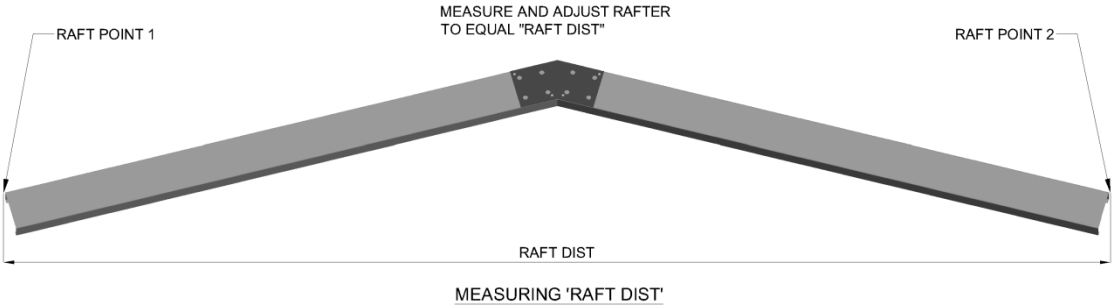

RAFTERS TO MEET AT LOWER END

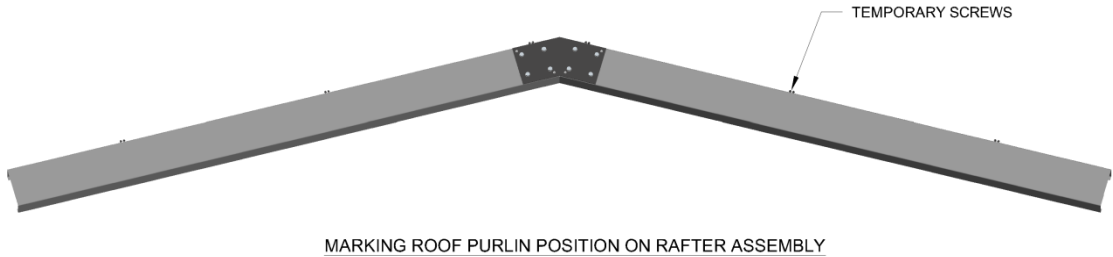

**MARKING ROOF PURLIN POSITION ON RAFTER ASSEMBLY**

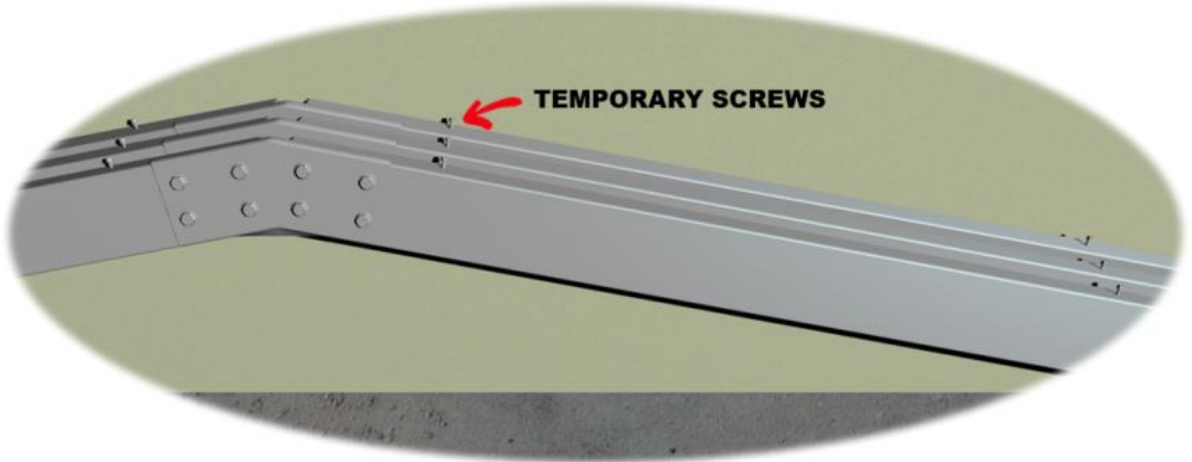

TIP: The outer web of the Front and Rear portal frames should face towards the centre of the building for aesthetics and attachment of Endwall Mullion purposes.

TIP: For intermediate frame with double rafter application, 2 apex brackets are to be used and attached to the webs of the double rafters with fastening type as per Engineering Plans.

## 14 Fitting of Columns with Haunch Bracket

Layout Columns and Haunch Brackets on the slab. Ensure that the haunch bracket punching end of the column is at the top. This can be achieved by matching the punching in the haunch bracket against the punching in the column.

Lay the Column flat on the slab, web face up. Attach the Haunch Bracket to the top end of the column, web face up. Keep the haunch bracket temporarily in place with 2 frame tek screws. Repeat procedure to the rest of the columns. Stand the column on the flange and permanently bolt the haunch bracket to the column.

Mark the spacing of the sidewall girts in the column flanges, spacing as per the Engineering Plans with the first girt being 250mm above the floor level.

./Options/Fixing Bolted

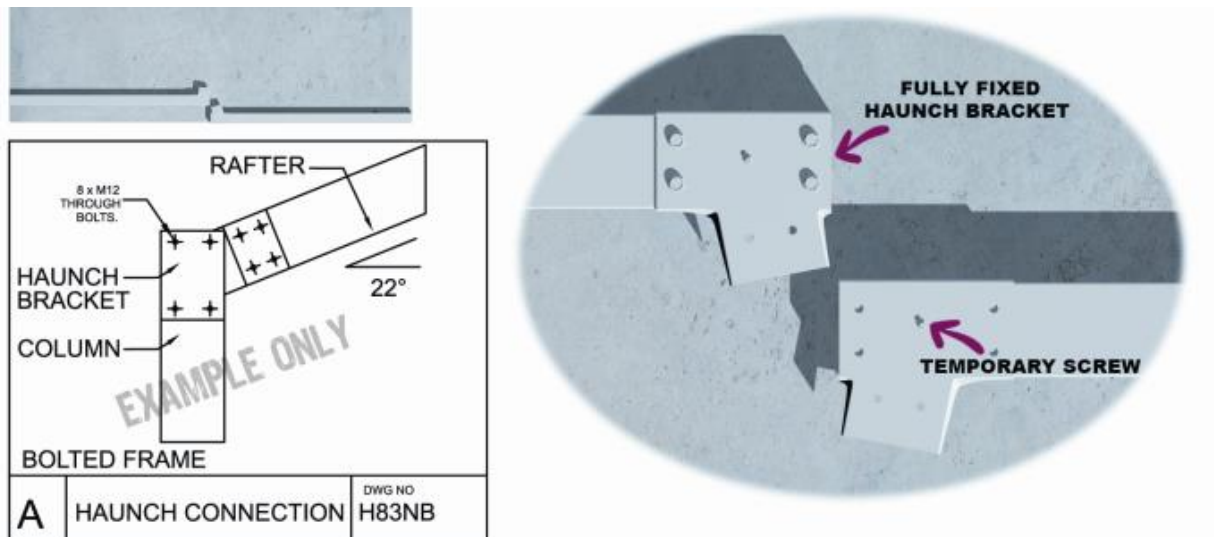



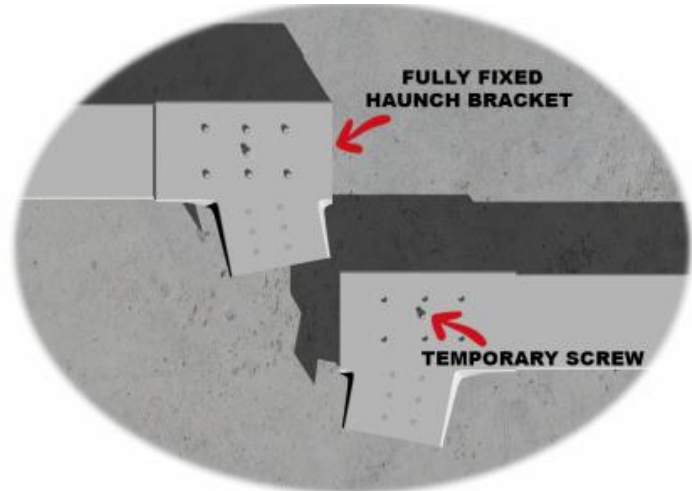
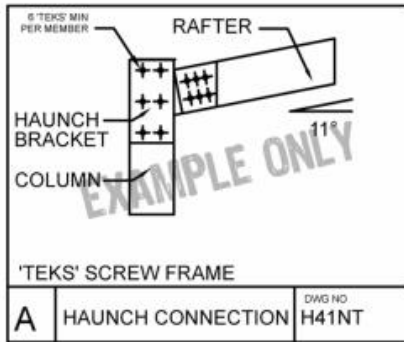
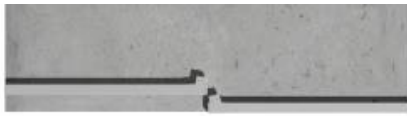

TIP: Layout the haunch brackets web face up to determine the Left and Right Haunch Bracket. Where the column attachment is on the left, it is the Left Haunch Bracket and where the column attachment is on the right, it is the Right Haunch Bracket.

TIP: IF STRUCTURE HAS MEZZANINE FLOOR AND HAS DOUBLE COLUMNS, IT IS RECOMMENDED TO FIT THE SINGLE MEZZANINE FLOOR BRACKET IN BETWEEN THE COLUMNS WHILST THE HAUNCH BRACKET IS BEING FITTED WITH FASTENING TYPE AS PER ENGINEERING PLANS. ENSURE THAT THE MEZZANINE BEARER BRACKET IS FIXED TO THE CORRECT HEIGHT ON THE COLUMN. REFER TO MEZZANINE FLOOR CHAPTER FOR PROCEDURE.

## 15 Fitting of Columns with Eave Purlin Bracket

Lay the column as shown and fix the eave purlin bracket to the lip and web side of the C-Purlin column with frame tek screws each side on a single frame application. On a double frame application, the eave purlin bracket attaches to the lips of the columns. Refer to Engineering Plans on the height specifications of the Eave Purlin Bracket. Repeat this procedure to the other columns.

## FITTING OF COLUMNS WITH EAVE PURLIN BRACKET

**SINGLE COLUMN EAVE PURLIN BRACKET CONNECTION**

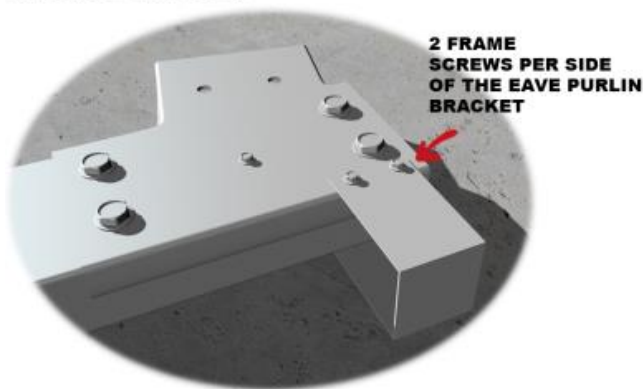

**DOUBLE COLUMN EAVE PURLIN BRACKET CONNECTION**

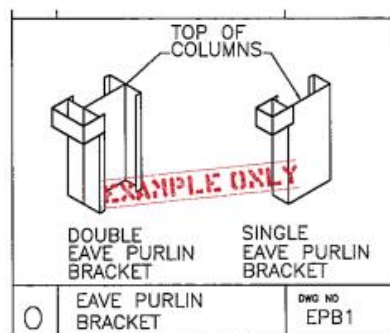
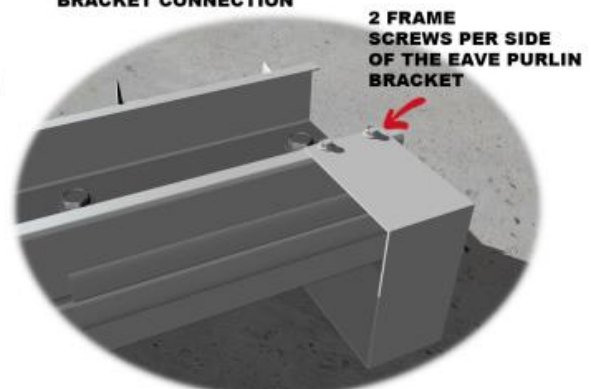

TIP: C-Eave Purlins are butt jointed when attached to Eave Purlin Bracket.

## 16 Portal Frame Assembly

Following the attachment of Haunch Bracket to Column, Eave Purlin Bracket (EPB) to Column, Apex Bracket to Rafters to form an Apex, Column and Rafter are now ready to be assembled to create a Portal Frame.

Layout the pre-assembled rafter on the ground placing the end of the rafters under each haunch bracket.

If Apex Brace is required, attach it to the 2 rafters. Refer to Engineering Plans in Member and Material Schedule for apex brace size, length and position from the rafter end.

Attach the rafter ends into the pre-assembled column-haunch bracket. Repeat the Haunch Bracket attachment to the other Rafter end. Do not tighten until the overall width of the columns has been checked against the "Raft-Dist" criteria in "Marking Out the Building" Chapter. Check Portal Frame for square by diagonal measurement then tighten the connections.

If Knee Brace is required, attach it to the column and rafter. Refer to Engineering Plans in Member and Material Schedule for Knee Brace size, length, height up to the column and rafter and all other Knee Brace specifications.

Mark the spacing of the Sidewall Girts on the column flanges, spacing as per the Engineering Plans with the first girt being 250mm above the Column if Column is NOT embedded. If Column is embedded, first girt being 250mm above the Finish Floor Line.

Ensure that all the bolts to the brackets are tightened.

The first Portal Frame Assembly is now complete and ready to stand.

Repeat the procedure to the remaining Columns and Rafters.

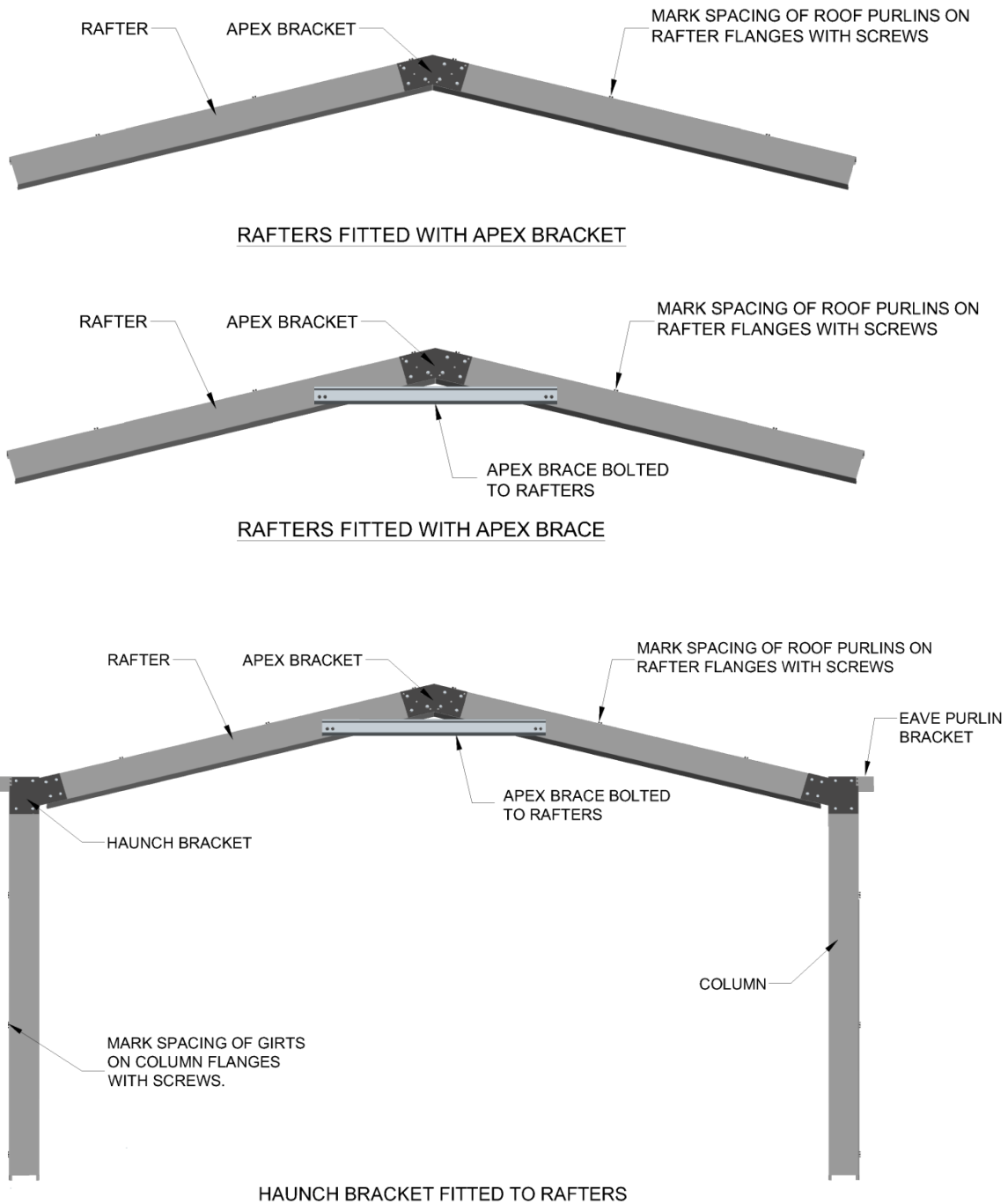

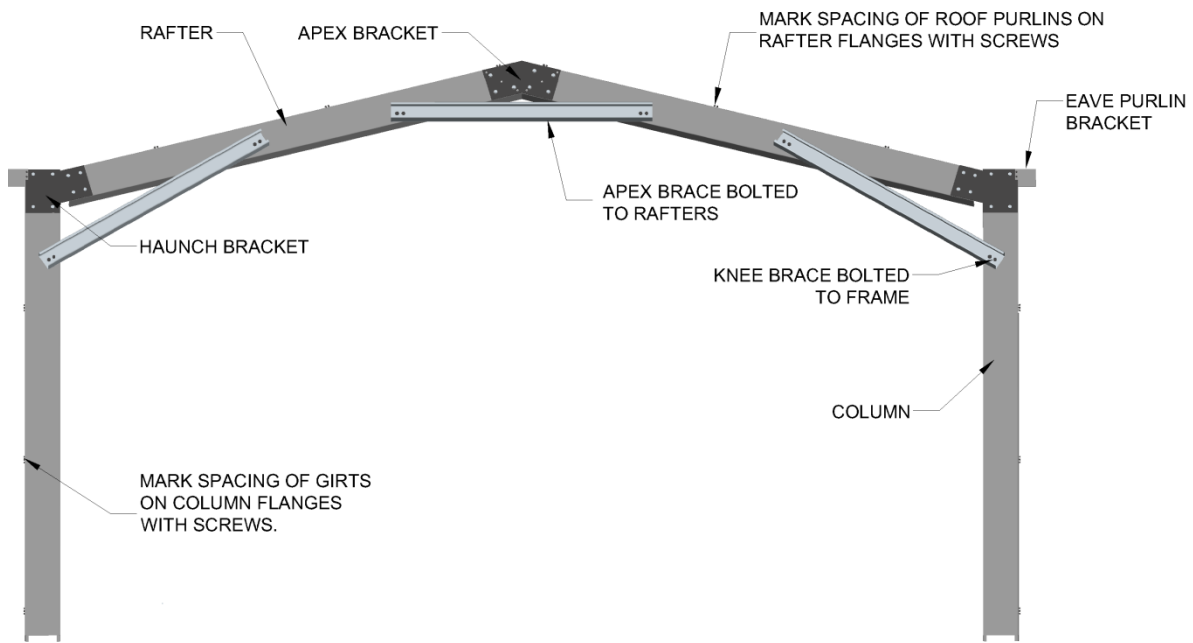

KNEE BRACE FITTED TO COLUMN AND RAFTER  
(COMPLETE PORTAL FRAME ASSEMBLY)

## 17 Fixing of Apex Brace

Fit Apex Brace as required. The image as shown below is a guide on the criteria of placement of the Apex Brace. The length of Apex Brace supply can be longer in some instances for added allowance for bolt fixing requirements. Refer to the Engineering Plans for the specifications and fastening type of Apex Brace.

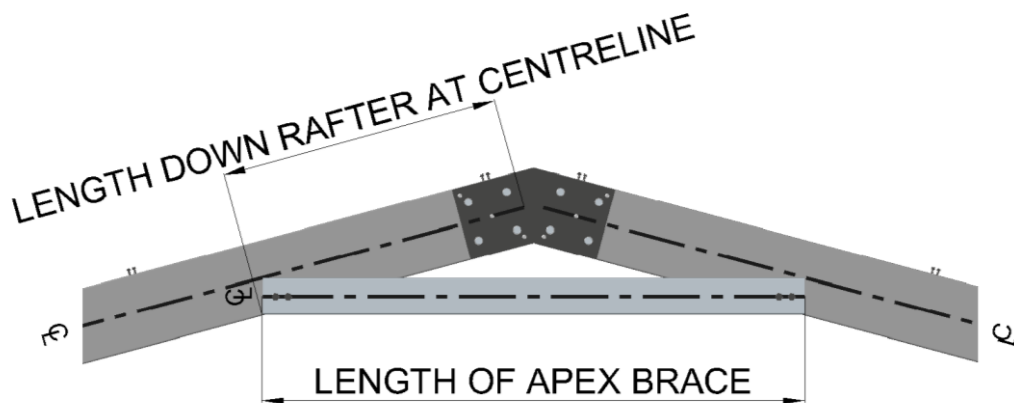

**Flanges not notched** – This option is to have the webs of Apex Brace attach to the webs of the Rafter facing the opposite direction of the Rafter.

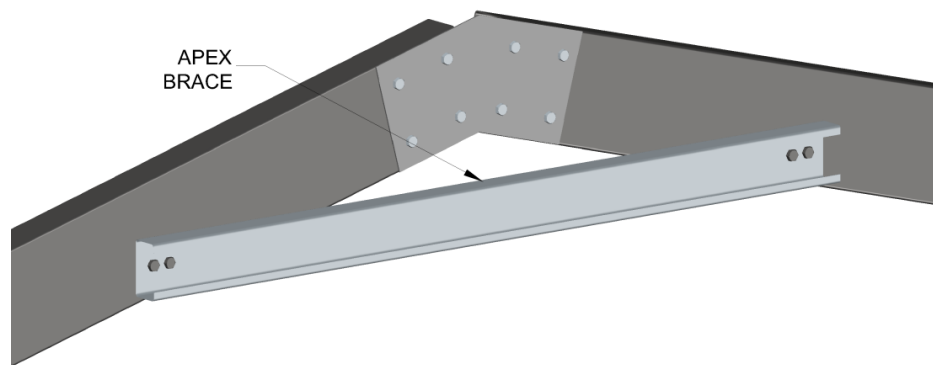
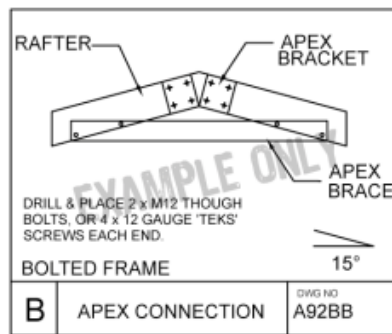

FIXING OF APEX BRACE

**Flanges notched** – This option is to notch the flanges of the Apex Brace, attach to the webs of the Rafter facing the same direction of the Rafter.

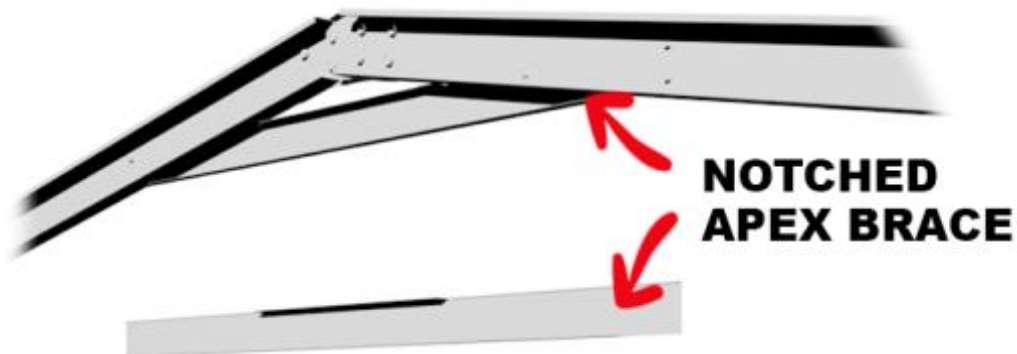

NOTE: Refer to the Engineering Plans for the specifications and fastening type of the Apex Brace.

## 18 Fixing of Knee Brace

Fit Knee Brace as required. The image as shown below is a guide on the criteria of placement of the Knee Brace. The length of Knee Brace supply can be longer in some instances for added allowance for bolt fixing requirements. Refer to the Engineering Plans for the specifications and fastening type of Knee Brace.

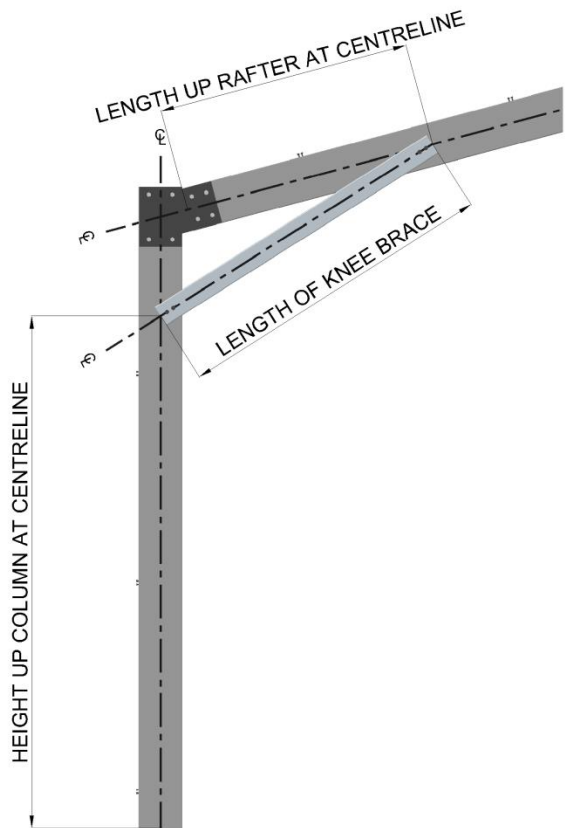

**For Double Portal Frame and Double Brace application** – Notch the flanges of the double Knee Brace, insert between the double frame facing the same direction as the double rafter and column.



NOTE: Refer to the Engineering Plans for the specifications and fastening type of the Knee Brace.

## 19 Standing the First Portal Frame Assembly

WARNING: DO NOT ATTEMPT TO STAND A PORTAL FRAME ASSEMBLY ON WINDY DAYS. CAUTION SHOULD BE OBSERVED AND SAFETY TO BE THE UTMOST PRIORITY WHEN STANDING A PORTAL FRAME ASSEMBLY.

NOTE: COLUMN AND RAFTER CONFIGURATIONS ARE INDICATIVE ONLY. REFER TO ENGINEERING PLANS FOR COLUMN AND RAFTER SPECIFICATIONS.

With the assistance of other installers, lift the first Portal Frame Assembly into position and ensure that the columns are flush with the edge of the concrete slab. Open side of the Frame to face outside. Position the inside face of the column flange to the chalk line previously marked on the concrete slab. Refer to “Marking Out the Building” chapter for reference of the “chalk line”. Brace and prop both ends and side of the portal frame assembly with the appropriate temporary bracing material tied securely around stakes or equivalent driven into the ground. The portal frame should be supported temporarily until all frames and end mullions are in place to stop the rafters rotating on the haunch brackets. Refer to “Guide to the Installation of Temporary Bracing”.

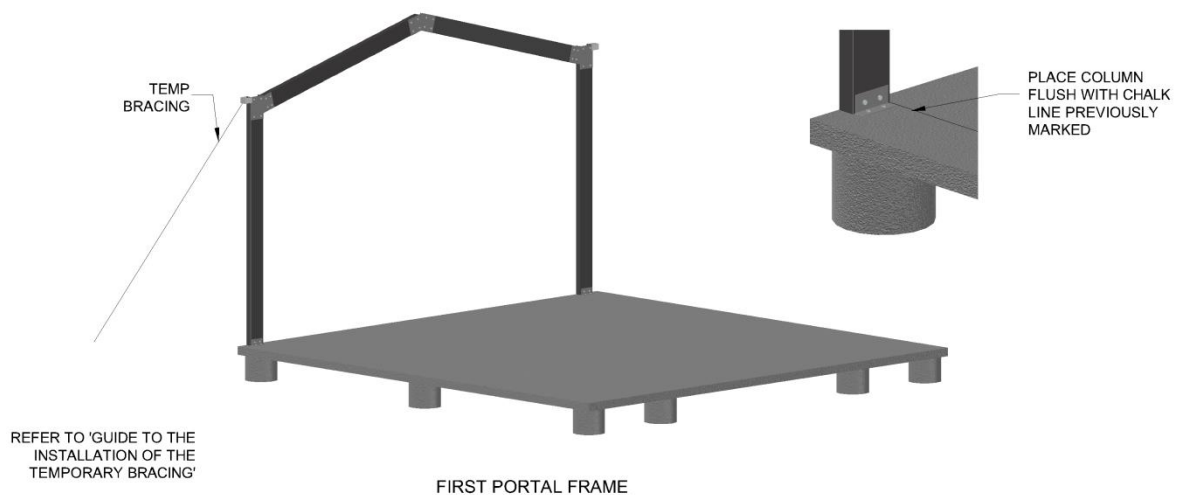

After the Portal Frame is stood up, ensure that the column is between the Hold-Down Bracket set in concrete. Match the holes of the column flanges punching to the holes of the Hold-Down Bracket. Secure with appropriate fastening type as per the Engineering Plans. Refer to Corner Section Footing Detail in the Bolt Layout of the Engineering Plans for a non-standard footing arrangement. Brace the Frame as per the “Guide to the Installation of Temporary Bracing”.

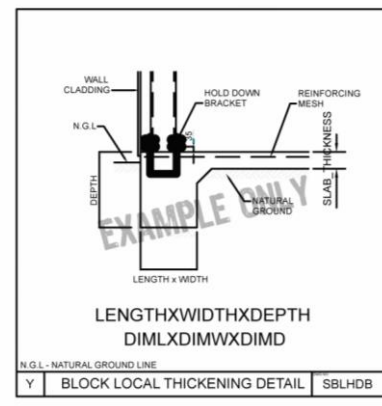
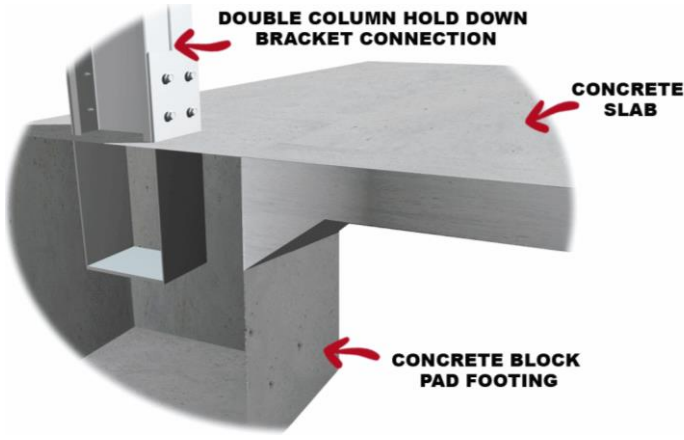
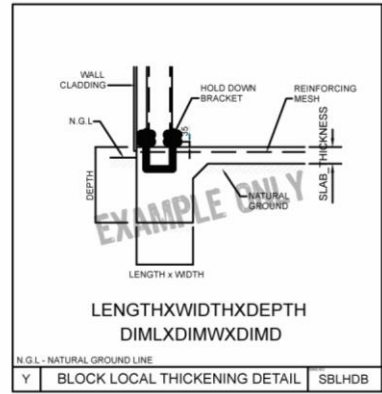
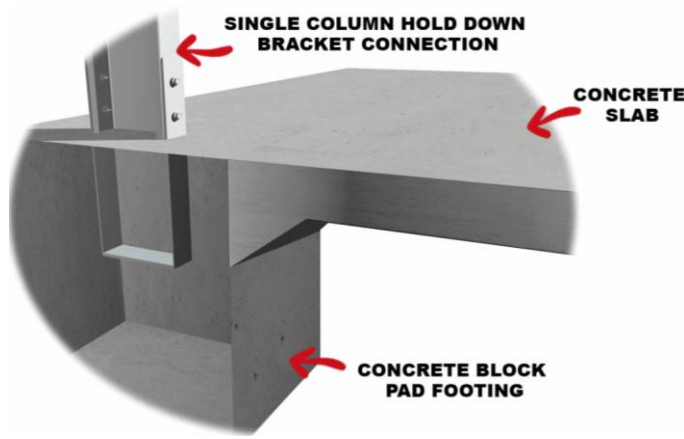

## 20 Installation of Endwall Mullion

NOTE: COLUMN AND RAFTER CONFIGURATION ARE INDICATIVE ONLY. REFER TO ENGINEERING PLANS FOR COLUMN AND RAFTER SPECIFICATIONS.



## INSTALLATION OF END WALL MULLION

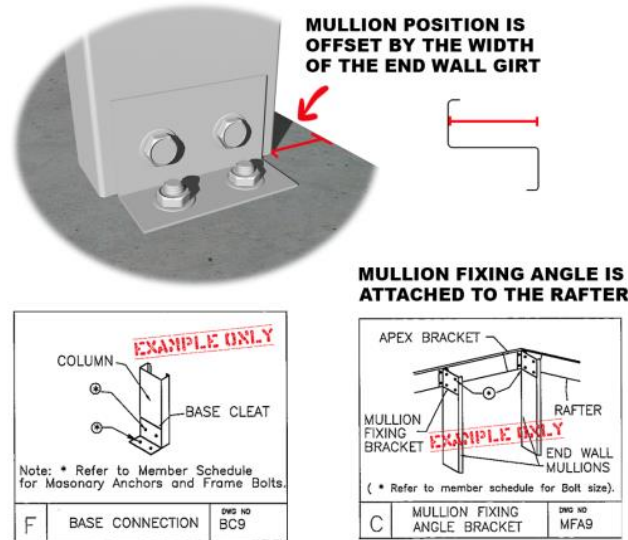

Fix the base cleat to the outer web base of a single Endwall Mullion with Fastening Type as per Engineering Plans. For double Endwall Mullion application, fix the base cleat to the inner web base of each column. The Endwall Mullion location is offset by the width of the end wall girt from the edge of the slab and is positioned perpendicular to the Rafter. Drill holes through the base cleat attached to each column to the concrete and secure with appropriate Fastening Type as per Engineering Plans. Attach the longer leg of the Mullion Fixing Angle (MFA) bracket to the top end of the Mullion on the outer web face with the shorter leg of the MFA attached to the outer web face of the Rafter with the Fastening Type specified on the Engineering Plans. The number of Mullions varies and is specified on the Engineering Plans.

**TIP:** The Endwall Mullion flange being perpendicular to the rafter may not necessarily be adjacent to the rafter as the distance of the Endwall Mullion is determined by the width of the end wall girt from the edge of the slab. Hence, the shorter leg of Mullion Fixing Angle is attached to the rafter web to take up the gap.

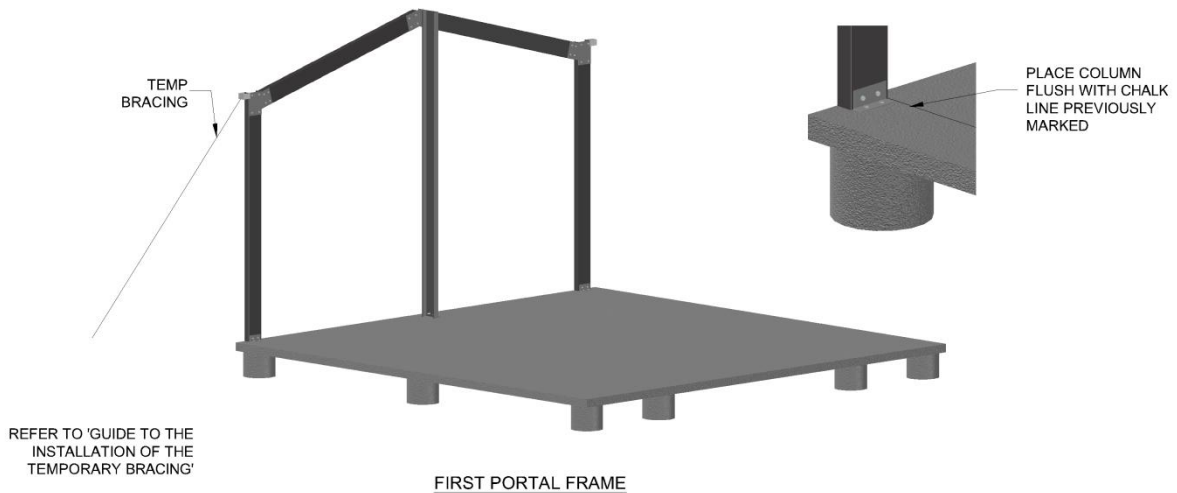

## 21 Standing The Second Portal Frame Assembly

Repeat the procedure in “Standing The First Portal Frame Assembly” Chapter .

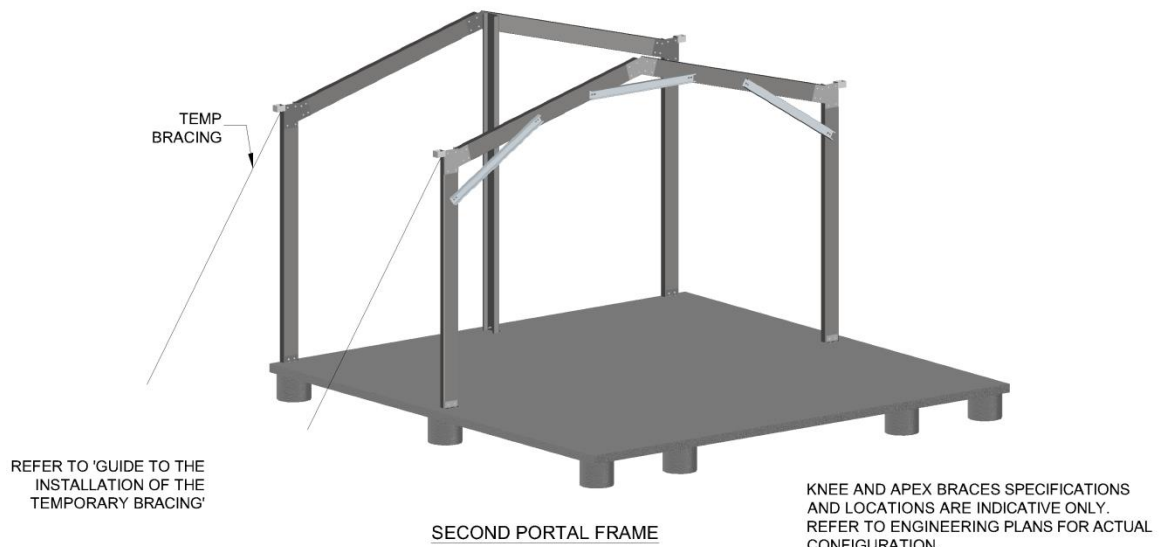

## 22 Standing All Portal Frame Assembly

NOTE: APEX AND KNEE BRACE CONFIGURATIONS ARE INDICATIVE ONLY. REFER TO ENGINEERING PLANS FOR SPECIFICATIONS.

Repeat the procedure in “Standing The First Portal Frame Assembly” Chapter .

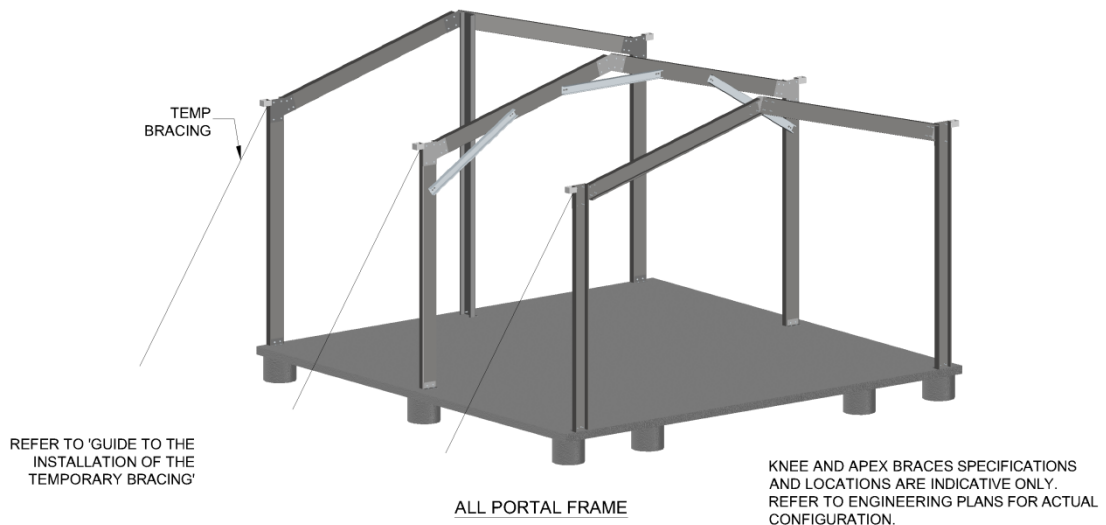

## 23 Fitting of C-Eave Purlin

### C-EAVE PURLIN CONNECTION

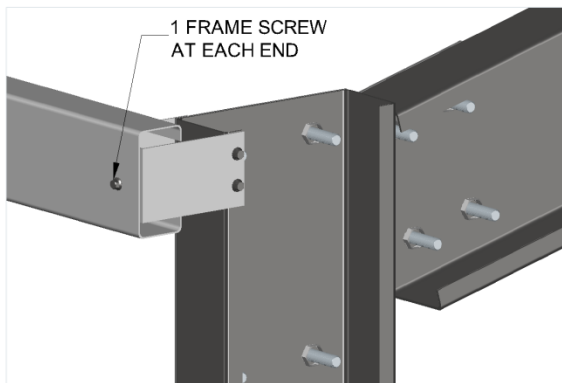

EAVE PURLIN CONNECTION AT END WALL COLUMN

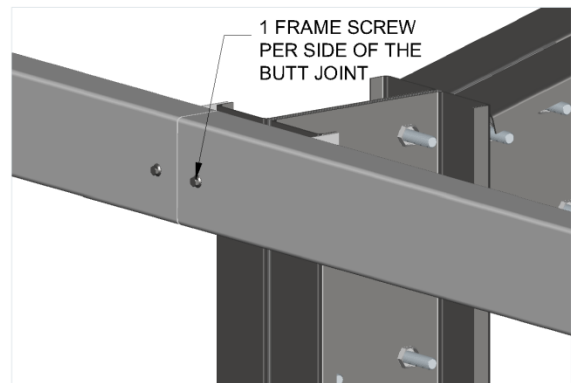

EAVE PURLIN CONNECTION AT INTERMEDIATE COLUMN

Attach the C-Eave Purlin to the Eave Purlin Bracket with 2 tek screws. If a joint is required in the intermediate column, joint should be butt joint with 2 frame screws each side of the Eave Purlin. Refer to Engineering Plans on the height specifications and fastening type of the C-Eave Purlin. Repeat this procedure to the other columns.

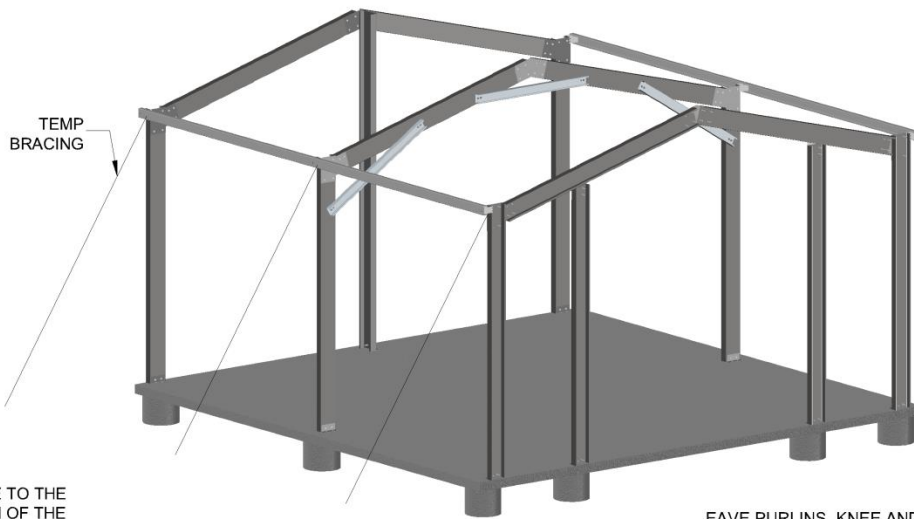

REFER TO 'GUIDE TO THE INSTALLATION OF THE TEMPORARY BRACING'

EAVE PURLINS, KNEE AND APEX BRACES SPECIFICATIONS AND LOCATIONS ARE INDICATIVE ONLY. REFER TO ENGINEERING PLANS FOR ACTUAL CONFIGURATION.

FIXING OF EAVE PURLIN - C SECTION

## 24 Fixing of Roof Purlins

Lift the pre-joined roof purlins into the rafters to line up with the temporary screws of the rafters for the purlin location. Roof purlin ends to flush with the outer face of the rafters on gable endwalls. Attach the roof purlins with one screw per connection initially. Ensure that gable endwall rafters and all intermediate rafters are plumb prior to purlins being permanently attached. Refer to Engineering Plans for purlin spacing. If roof strap bracing is required, fix into position as per Engineering Plans prior to laying sheets on the roof.

**TIP:** Purlin spacing is not necessarily the same as the girt spacing so it is imperative to refer to the Engineering Plans.

**NOTE:** COLUMN AND RAFTER CONFIGURATIONS ARE INDICATIVE ONLY. REFER TO ENGINEERING PLANS FOR COLUMN AND RAFTER SPECIFICATIONS.

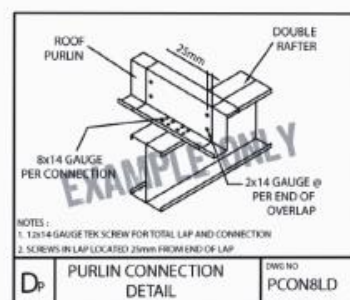
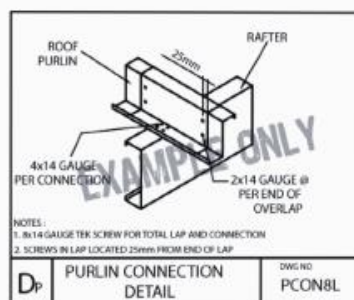

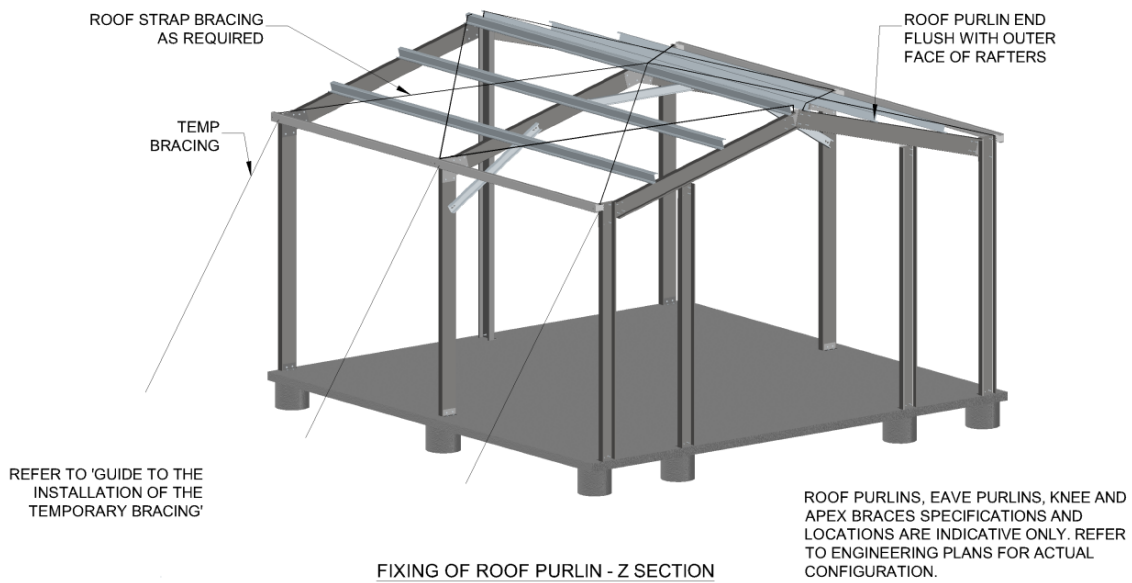

## 25 Fixing of Endwall Girts

End wall girt to finish flush with the outer face of the end columns. Attach the end girt with end girt bracket to the column flange. Lift the wall girts in between the end columns. If endwall mullion is present, attach the girt directly to the flange of the endwall mullion. Ensure that the end columns are plumb prior to the girt being permanently attached. Refer to Engineering Plans for girt spacing and lap. If wall strap bracing is required, fix into position as per Engineering Plans prior to laying sheets on the wall.

**TIP:** Purlin spacing is not necessarily the same as the girt spacing so it is imperative to refer to the Engineering Plans.

**NOTE:** COLUMN AND RAFTER CONFIGURATIONS ARE INDICATIVE ONLY. REFER TO ENGINEERING PLANS FOR COLUMN AND RAFTER SPECIFICATIONS.

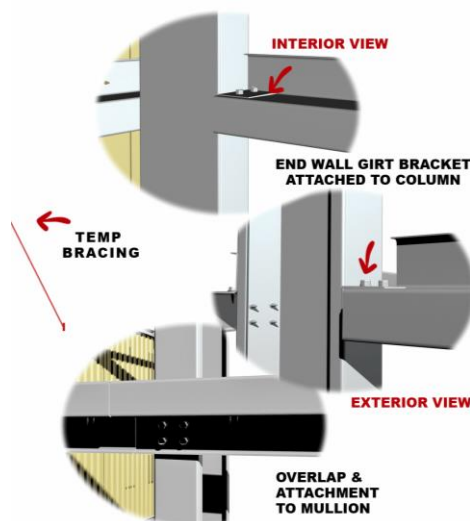

12	MAIN BLDG. PURLIN LENGTH	4.4 m. (0.4m Overlap)
13	TYP. SIDEWALL GIRT LENGTH	7.8m (0.4m x 1.0)
14	MAIN BLDG. SIDEWALL GIRT SPACING	2.0 m.
15	MAIN BLDG. SIDEWALL GIRT LENGTH	4.4 m. (0.4m Overlap)
16	TYP. SIDEWALL GIRT SIZE	10gphst 54 x 1.0
17	MAIN BLDG. ENDWALL GIRT SPACING	1.2 m.
18	MAIN BLDG. ENDWALL GIRT LENGTH	3.3 m. (0.48m Overlap)
19	FRAME SCREW FASTENERS	14-13x22 Hex C/S (SP HD 5/16" Hex Drive)

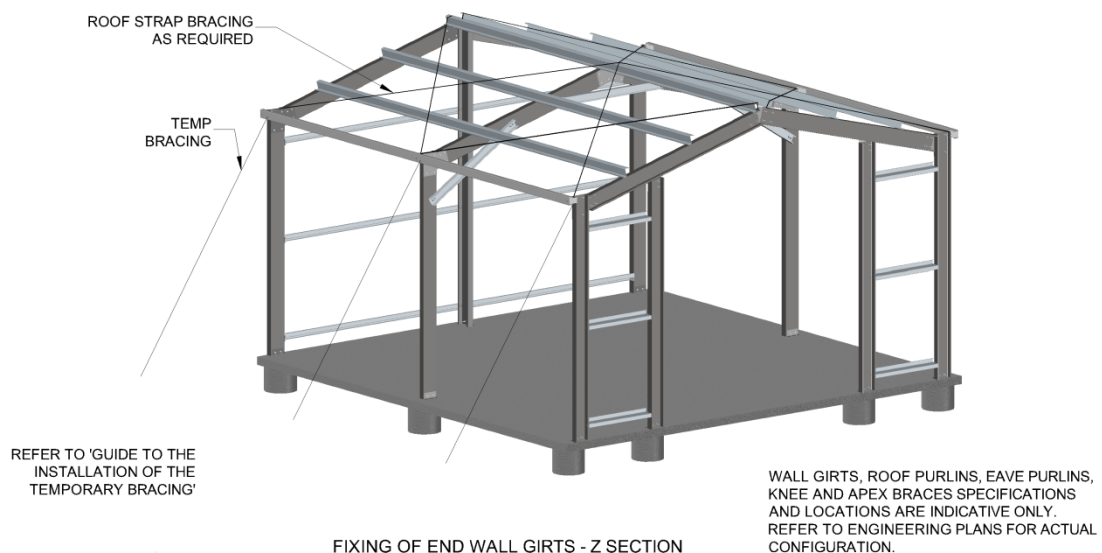

## 26 Fixing of Sidewall Girts

Fit the pre-joined sidewall girts to the column flange to line up with the temporary screws in the columns for the girt location. The first girt being 250mm above the floor level and spacing as per Engineering plans. Sidewall girt ends to flush with the outer face of the end columns which is equal to the length of the concrete slab. Attach girts with one screw per connection initially. Ensure that end column and all intermediate columns are plumb prior to girts being permanently attached. Refer to Engineering Plans for girt spacing and framing screw specifications. If wall strap bracing is required, fix into position as per Engineering Plans prior to laying sheets on the wall.

**TIP:** Girt spacing is not necessarily the same as the purlin spacing so it is imperative to refer to the

Engineering Plans.

NOTE: COLUMN AND RAFTER CONFIGURATIONS ARE INDICATIVE ONLY. REFER TO ENGINEERING PLANS FOR COLUMN AND RAFTER SPECIFICATIONS.

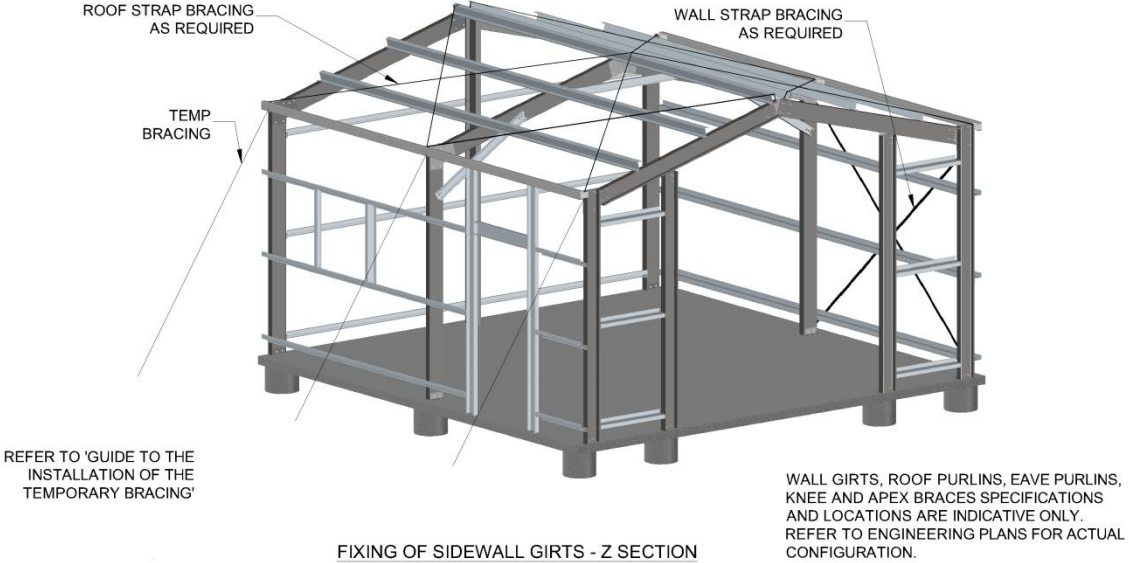
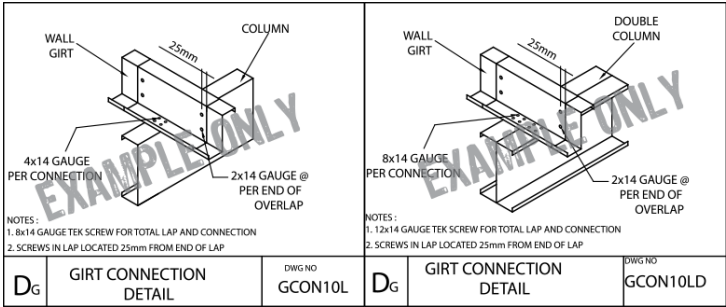

## 27 Fixing of Strap Bracing

Fix Wall Strap Bracing from the high end of column to the base of the next Column, diagonally, as required.

Fix Roof Strap Bracing from the lower end of the Rafter to the ridge end of the Rafter as required. Refer to the Engineering Plans on the specifications and exact locations of the bracing strap on both Rafters and Columns.

**TIP: Refer to Engineering Plans for the wall strap brace layout of window and door openings.**

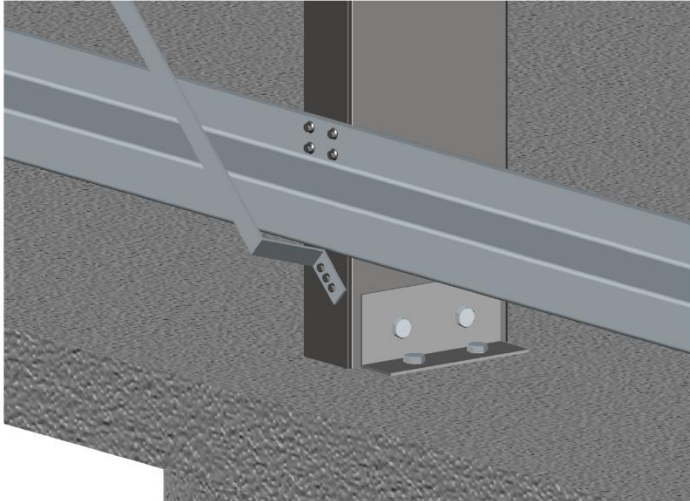
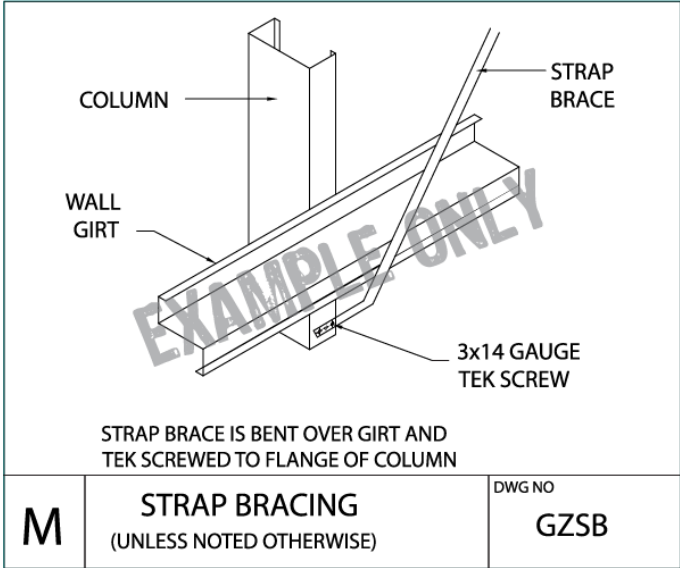

FIXING STRAP BRACE TO WALL



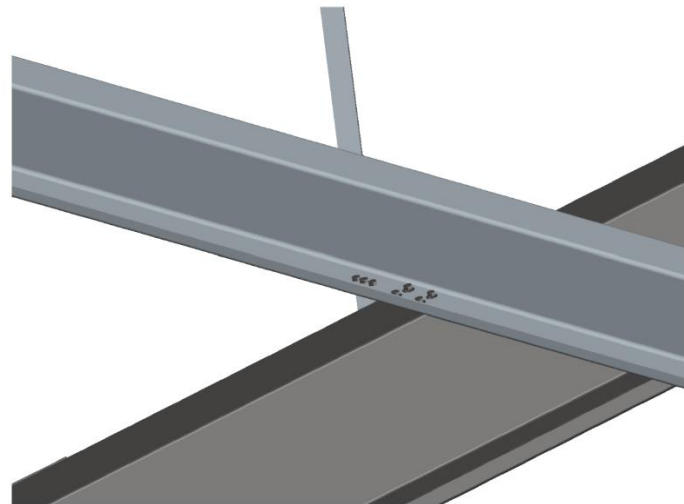
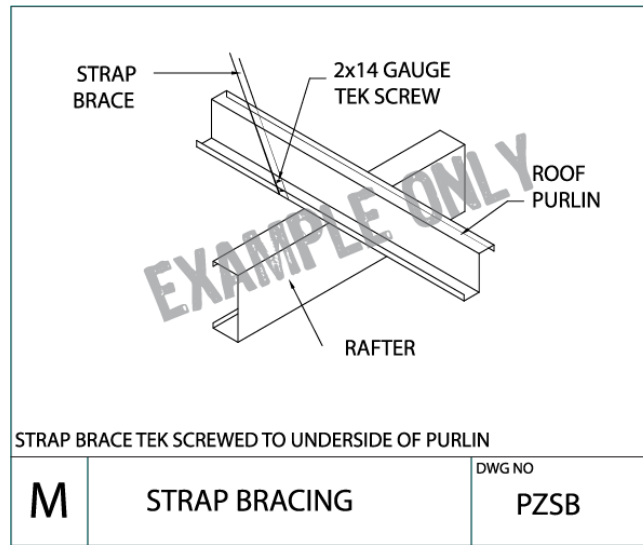

FIXING STRAP BRACE TO ROOF

## 28 Fixing of Fly Bracing

Fit the Fly Bracing around the Column and Rafter flanges to the lip of a tophat purlin and tophat girt as required.

Fit the Fly Bracing around the Column and Rafter flanges to the flange of a Z-purlin and a Z-girt as required.

Refer to the Engineering Plans for the location and detail of fly bracing.

## FLY BRACING

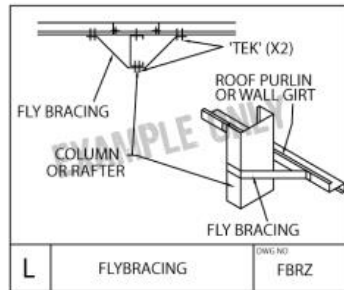

## 29 Installation of Sidewall Roller Door Frame

NOTE: Refer to Manufacturer's Specifications and Installation Procedure.

**NOTE: Installation of Sidewall Roller Door Jambs and Header should occur after the sidewall girts are in place. The pre-installed side wall sheets for the "Tilt Up Method" will need to be cut to suit the roller door opening in the location required.**

**NOTE: Installation of Sidewall Roller Door and Associated Parts should occur after flashings and downpipes have been fixed.**

**POSITION** – Sidewall Roller Doors can be positioned between two intermediate columns within a "bay". If the roller door is to be offset to either Left or Right of the bay, a minimum of 100mm has to be allowed for from the door opening to the inner web or lip face of the nearest column for the roller door brackets. Any wall strap bracing affected by the position of the opening will need to be adjusted or moved to satisfy structural requirements.

**OPENING SIZE** – Refer to Manufacturer's Specifications on how to determine the Opening Size. Opening size is smaller than the Roller Door size due to allowance of door tracks and the roller drum. Once the opening size is determined, mark the position of the door jambs in the slab. Wall girts may need to be cut to suit the opening width.

### SIDE WALL ROLLER DOOR JAMB CONNECTIONS

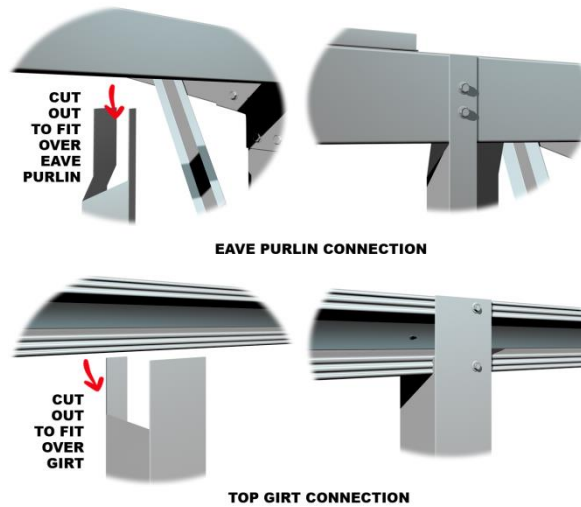

**ROLLER DOOR JAMBS** – Depending on the height of the sidewall roller door, the notched top part of the jamb can either be attached to the next wall girt or to the eave purlin whichever is applicable. The door jambs are supplied in stock lengths and has to be cut and notched out to suit the next support above the door. The web part of the jamb has to be notched out and the 2 upright legs attached to two sides of either the wall girt or the eave purlin whichever is applicable. Ensure that the longer leg of the jamb faces inside the building. Ensure that the jambs are plumb prior to fixing the base cleat at the bottom of the roller door jamb and masonry anchor to the slab. Fit both Left Hand and Right Hand roller door jambs as per marked position.

### SIDE WALL ROLLER DOOR CONNECTIONS



**ROLLER DOOR HEADER** – The height of the door header is equivalent to the door height opening required as previously determined. Measure and mark the height of the header to the two sides of the door jambs already in place. Fit the C-Purlin Door Header between the jambs with endwall girt brackets and framing screws. Trim the wall sheeting already in place to suit the required opening size.

**TRIM** – After the opening has been permanently fixed, complete the trims and flashings around the perimeter of the opening.

**SIDEWALL ROLLER DOOR** – Refer to Manufacturer’s Specifications and Installation Procedure for the installation of the Sidewall Roller Door and Associated Parts.

### SIDE WALL ROLLER DOOR



Z-Jamb is used as a Sidewall Roller Door jamb when a standard folder door jamb is not structurally sufficient. The size of the Z jamb is relative to the frame and girt size. Refer to table below.

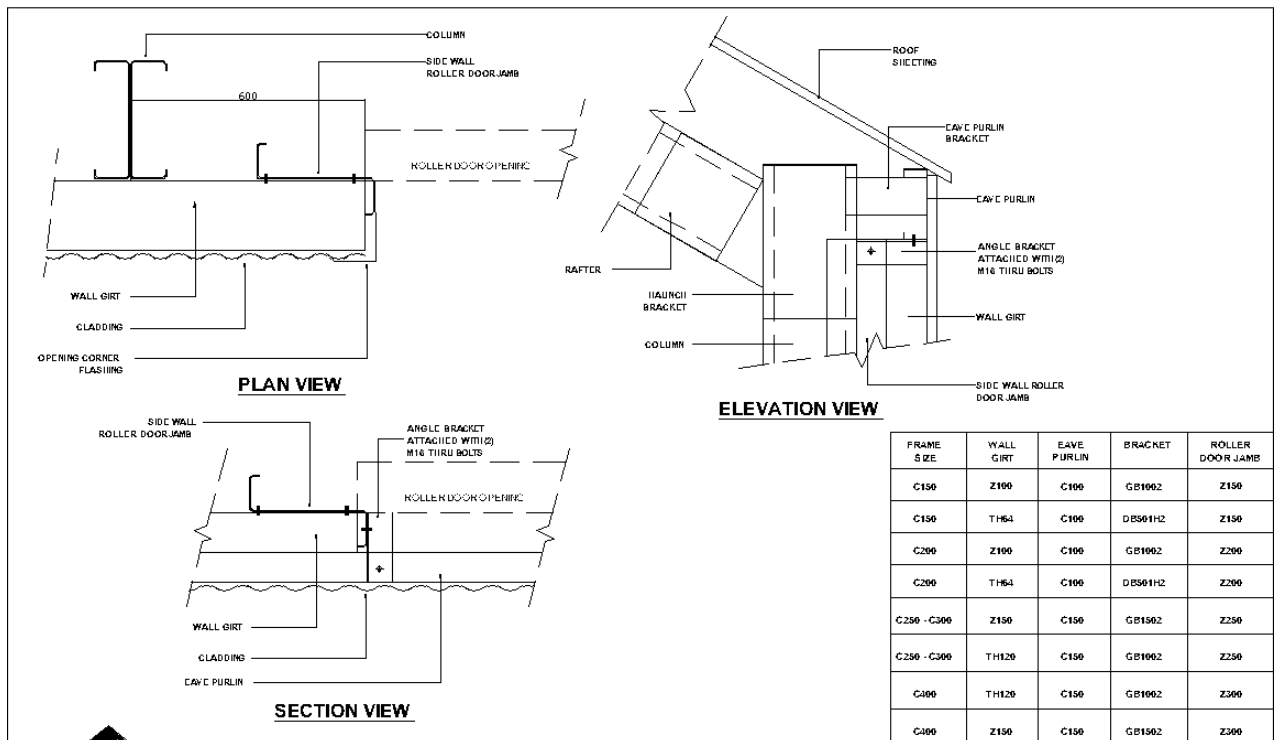

## 30 Fixing of Sidewall Sheets

Lay the sidewall sheets and ensure that the female rib faces away from the prevailing weather. Fix the wall sheets to wall girts one at a time with fastening type and specifications as per the Engineering Plans. Use a straight edge chalk line to ensure screws are in a straight line. Each end wall sheet to finish flush to the outer face of the end column or the end girt.

NOTE: If wall strap brace or fly brace is required, fix into position first prior to fixing the wall sheeting. Refer to the Engineering Plans for specifications and location of the wall strap brace and fly brace.

NOTE: Prior to fixing the open bay header sheets into position, it is imperative to check that both sidewalls and endwalls are plumb and straight by using a string line along the inner face of the columns.

**CAUTION:** It is imperative to sweep the edge of the metal with a soft hair brush to remove “swarf” whenever the sheets are cut. Any remaining swarf on the sheets after cutting will cause rusting and may void the warranty.

**NOTE:** COLUMN AND RAFTER CONFIGURATIONS ARE INDICATIVE ONLY. REFER TO ENGINEERING PLANS FOR COLUMN AND RAFTER SPECIFICATIONS.

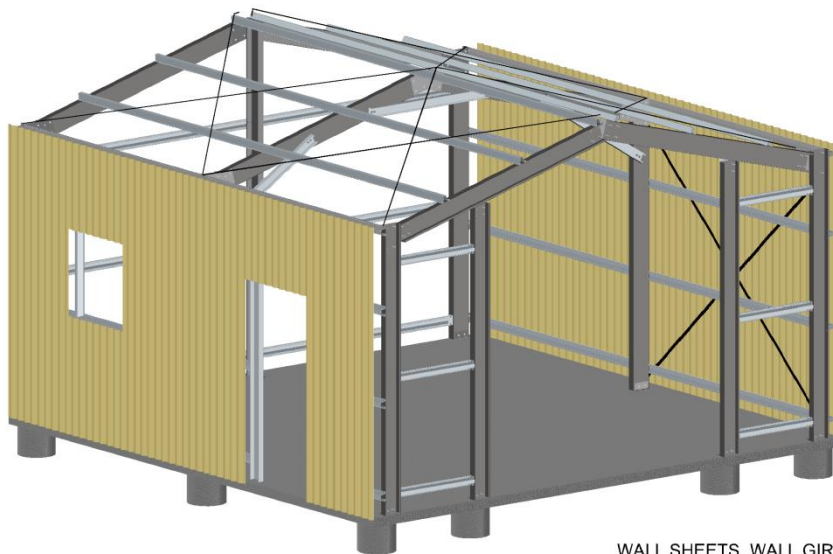

WALL SHEETS, WALL GIRTS, ROOF PURLINS, EAVE PURLINS, KNEE AND APEX BRACES SPECIFICATIONS AND LOCATIONS ARE INDICATIVE ONLY. REFER TO ENGINEERING PLANS FOR ACTUAL CONFIGURATION.

FIXING OF SIDE WALL SHEETS

## 31 Fixing of Endwall Sheets

Lay the endwall sheeting and ensure that the female rib faces away from the prevailing weather. Layout the Endwall Sheeting according to Multibuild’s sheeting layout recommendation. Attach the Endwall sheets at a time with the fastening type and specifications as per Engineering Plans. Use a straight edge or chalk line to ensure screws are placed in a straight line.

The endwall sheets should overlap the slab by 25mm to prevent water coming in the building. The bottom of the endwall sheets should line up with the bottom of the sidewall sheets. Fix the endwall sheets to wall girts one at a time with fastening type and specifications as per the Engineering Plans. Each last endwall sheet to finish flush to the outer face of the side wall girt.

Once all the endwall sheets are fixed into position, trim the top portion of the endwall sheets to flush with or slightly below the top of the purlins to follow the roof line with an electric nibbler or tin snips. Tek screw the trimmed top portion of the endwall sheets to the top lip of the rafter.

If there is an opening on the gable endwall, install and fix all the full wall sheets first and leave out the sheets where the opening is to be positioned. Once the location of the opening is established, fix all the sheets below or above the opening whichever is applicable.

**TIP:** Do not fit an opening until all sides of the wall frame are cladded.

**CAUTION:** It is imperative to sweep the edge of the metal with a soft hair brush to remove “swarf” whenever the sheets are cut. Any remaining swarf on the sheets after cutting will cause rusting and may void the warranty.

**NOTE:** FRAME COMPONENTS CONFIGURATIONS AND SPECIFICATIONS ARE INDICATIVE ONLY. REFER TO ENGINEERING PLANS FOR ACTUAL JOB SPECIFICATIONS.

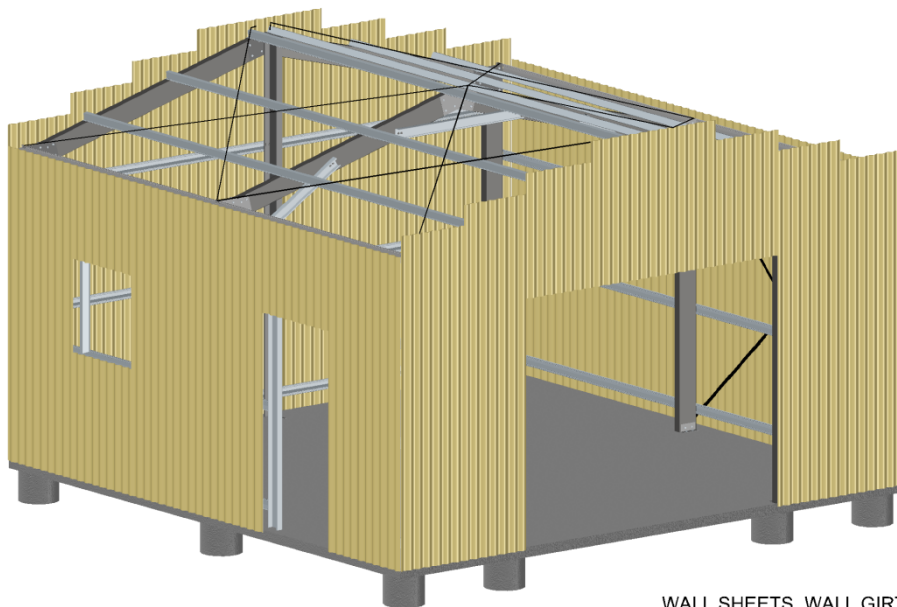

WALL SHEETS, WALL GIRTS, ROOF PURLINS, EAVE PURLINS, KNEE AND APEX BRACES SPECIFICATIONS AND LOCATIONS ARE INDICATIVE ONLY. REFER TO ENGINEERING PLANS FOR ACTUAL CONFIGURATION.

FIXING OF END WALL SHEETS

## 32 Fixing of Gutter

Gutter is to be fitted before the roof sheets are installed.

**CAUTION:** Use caution in handling cut steel as it is extremely sharp.

**TIP:** Gutter and gutter brackets may vary by area.

Position the gutter brackets spaced at 1.0meter maximum as a guide. Mark a chalk line from top of the wall sheets down to determine the height of the brackets, highest point of gutter bracket to line up with the top of wall sheeting. Attach the gutter brackets to the ribs of the wall sheets with pop rivets with a slight downward slope towards the downpipe. Apply silicone to joints of gutter prior to installation. Clip gutter into gutter brackets and ensure that the gutter overhang the gable end wall by the profile width of the sheets. Fold gutter bracket tags into the gutter to hold it into position.

NOTE: FRAME COMPONENTS CONFIGURATIONS AND SPECIFICATIONS ARE INDICATIVE ONLY. REFER TO ENGINEERING PLANS FOR ACTUAL JOB SPECIFICATIONS.

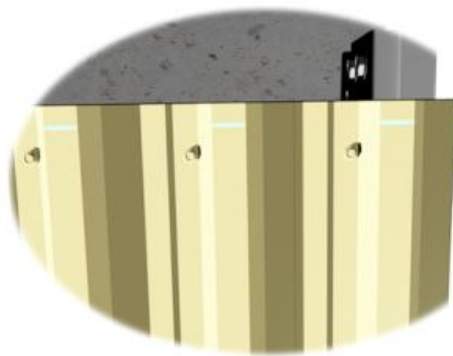

**MARK A CHALK LINE WITH A SLIGHT DOWNWARD SLOPE TOWARDS DOWNPIPE END**

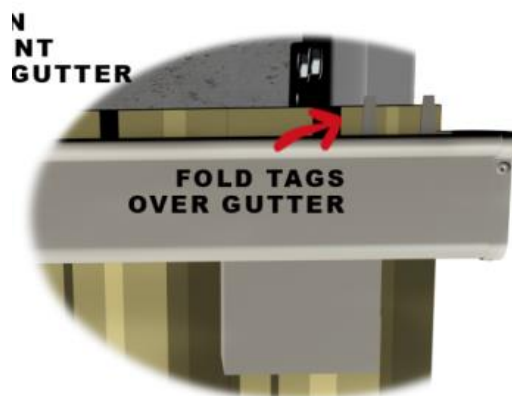

**STOP ENDS & DOWNPIPE NOZZLES**

TRACE INSIDE OF DOWNPIPE NOZZLE ONTO GUTTER AND CUT OUT USING TIN SNIPS

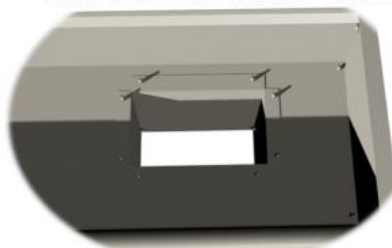

**ATTACH STOP ENDS AND DOWNPIPE NOZZLE WITH SILICONE & RIVETS**

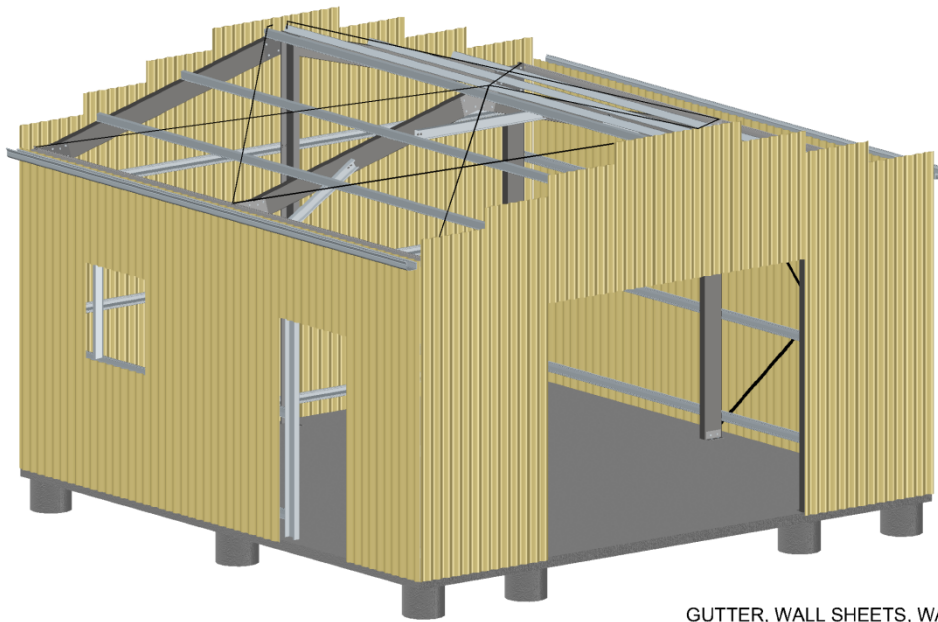

GUTTER, WALL SHEETS, WALL GIRTS, ROOF PURLINS, EAVE PURLINS, KNEE AND APEX BRACES SPECIFICATIONS AND LOCATIONS ARE INDICATIVE ONLY. REFER TO ENGINEERING PLANS FOR ACTUAL CONFIGURATION.

FIXING OF GUTTER

### 33 Fixing of Roof Sheets

Fix the roof sheeting and allow approximately half the gutter width or 50mm (whichever is lesser) to overhang into the gutter. Ensure that the female rib of the cladding faces away from the prevailing winds. Fix the roof sheeting with the required number of roof screws. Refer to Engineering Plans for roof specifications, roof screw specifications and spacing.

NOTE: Prior to fixing the roof sheeting into position, it is imperative to check that both sidewalls and endwalls are plumb and straight by using a string line along the inner face of the columns. Re-prop intermediate columns if necessary which helps the structure become more rigid while working on the roof.

NOTE: If skylight is required, it must be installed with safety precautions. Safety wire mesh is a requirement under the skylights. Refer to manufacturer's specifications and installation procedure for additional information.

TIP: Prior to fixing the roof sheeting to the purlins, turn up the sheeting along the ridge line with pliers for added protection from rain. This process is called "weathering" the sheets.

TIP: If roof strap brace or fly brace is required, fix into position first prior to fixing the roof sheeting. Refer to the Engineering Plans for specifications and location of the roof strap brace and fly brace.



TIP: If roof insulation is required, it must be installed first prior to roof sheets being fixed into position. Refer to manufacturer’s specifications and installation procedure for additional information.

CAUTION: It is imperative to sweep the edge of the metal with a soft hair brush to remove “swarf” whenever the sheets are cut. Any remaining swarf on the sheets after cutting will cause rusting and may void the warranty.

NOTE: FRAME COMPONENTS CONFIGURATIONS AND SPECIFICATIONS ARE INDICATIVE ONLY. REFER TO ENGINEERING PLANS FOR ACTUAL JOB SPECIFICATIONS.

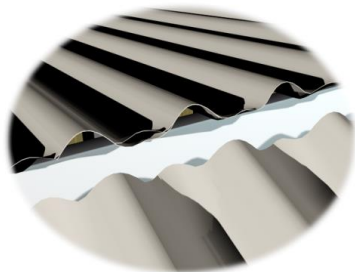

**“WEATHERING” ROOF SHEETS**

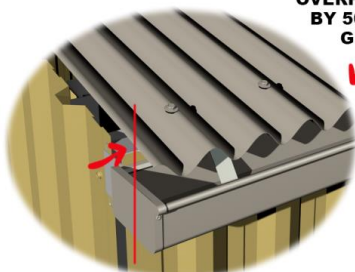
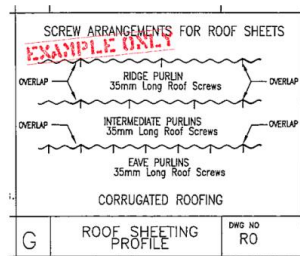

**ROOF SHEETS CUT FLUSH TO END OF GUTTERS**

**OVERHANG GUTTER BY 50mm OR HALF GUTTER WIDTH**

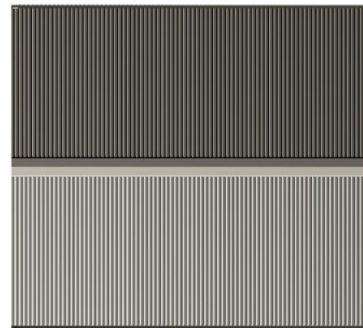

**ROOF SHEETS IN PLACE**

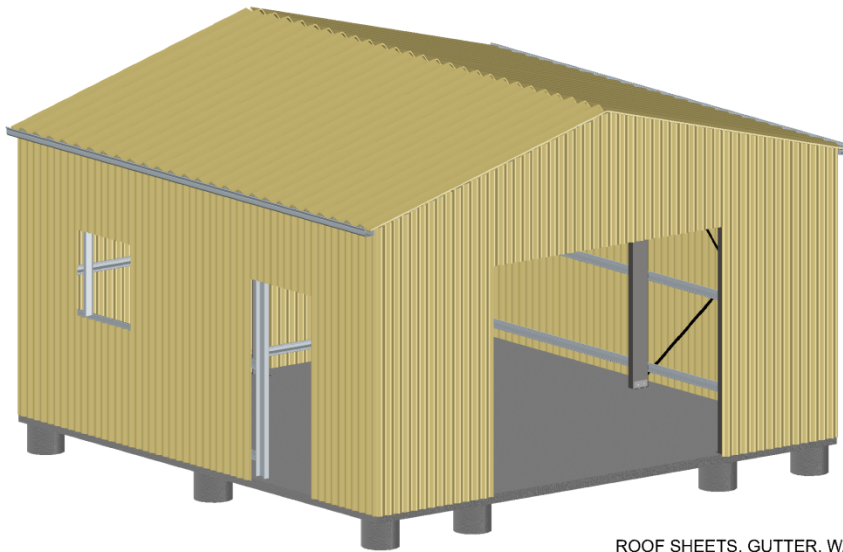

FIXING OF ROOF SHEETS

ROOF SHEETS, GUTTER, WALL SHEETS, WALL GIRTS, ROOF PURLINS, EAVE PURLINS, KNEE AND APEX BRACES SPECIFICATIONS AND LOCATIONS ARE INDICATIVE ONLY. REFER TO ENGINEERING PLANS FOR ACTUAL CONFIGURATION.

## 34 Fixing of Flashings

**CORNER FLASHING** – Fix all corner flashings with pop rivets or wall screws as required. Use the “Wall Sheeting Profile” screw arrangement and spacing as per Engineering Plans to fix the corner flashings. A wall screw or 35mm rivet from each end of corner flashing is required. Ensure that all the corner flashings are flush to the bottom of the wall sheets. Ensure that flashing is secure and watertight. Run a bead of silicone on the overlap and joints of the corner flashing.

**NOTE: BUILDING CONFIGURATION IS INDICATIVE ONLY. REFER TO ENGINEERING PLANS FOR ACTUAL BUILDING CONFIGURATION AND SPECIFICATIONS.**

## CORNER AND OPENING FLASHINGS

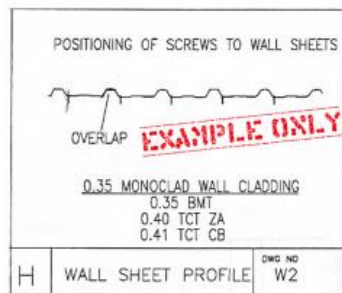

**BUILDING CORNER FLASHING**



**SCREWS AS PER WALL SHEETING PROFILE AND 35mm FROM EACH END**



**ROLLER DOOR OPENING**



**OPENING FLASHING** – Fix all opening flashings with pop rivets or wall screws as required. Use the “Wall Sheeting Profile” screw arrangement and spacing as per Engineering Plans to fix the opening flashings. A wall screw or 35mm rivet from each end of opening flashing is required. Ensure that all opening flashings are mitered at corners of openings. Ensure that flashing is secure and watertight. Run a bead of silicone on the overlap and joints of the opening flashing.

**BARGE CAP** – Fix the first left barge cap in position starting from the ridge line with pop rivets or wall screws whichever is applicable. Ensure that the top of the barge cap is in line with the centre of the ridge cap on the same angle as the roof pitch. Fix the vertical leg of the barge cap with pop rivets or wall screws to the ribs of the wall sheets. Fix the horizontal leg of the ridge cap to the roof purlins with roof screws. Use the “Roof Sheeting Profile” screw arrangement and spacing as per Engineering Plans. Fix the second right barge cap into position and allow a 10mm overlap of the horizontal leg on the roof from the centre of the ridge cap. Mark a vertical cutting line on the vertical face of the barge cap with a spirit level. Trim the excess barge cap to the marked line with tin snips to a plumb cut. Fasten the right barge cap in position with pop rivets or wall screws using the same “Roof Sheeting Profile” guide. Fold down the 10mm overlap of the horizontal leg over to the left barge cap. Run a bead of silicone on the overlap and joints of the barge cap.

**ATTACHING THE BARGE CAP**  
FIRST SIDE INSTALLED



**BARGE CAPPING COMPLETE**

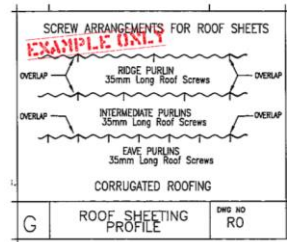

**FOLD DOWN 10cm OVERLAP ON HORIZONTAL LEG**



**RIDGE CAP** – Fix the ridge cap to the last roof purlin or to the roof sheets whichever is applicable on both sides of the ridge cap. Use the “Roof Sheeting Profile” screw arrangement and spacing as per Engineering Plans. Ensure that end of the ridge cap is flush to the outer face of the endwall cladding. Joints must face away from the prevailing wind. Run a bead of silicone on the overlap of the ridge cap.

**RIDGE CAP**

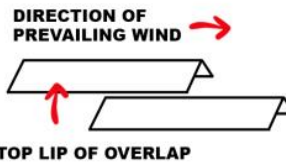
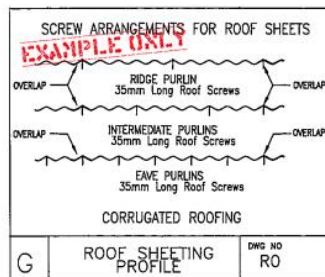

**ENSURE THE END OF THE RIDGE CAP IS FLUSH TO THE OUTSIDE OF END WALL CLADDING**

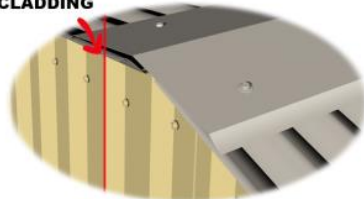

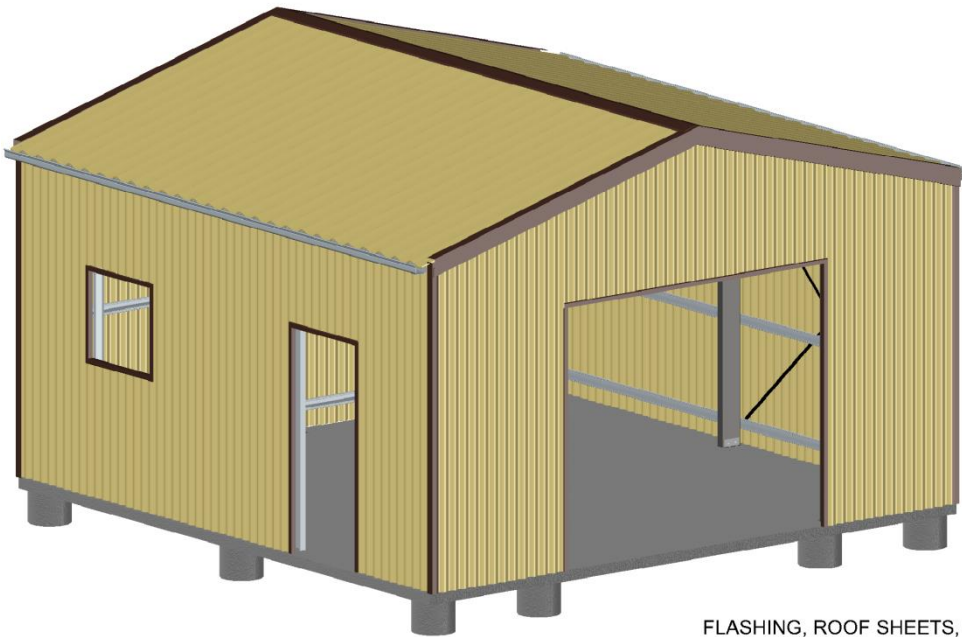

FIXING OF FLASHING

FLASHING, ROOF SHEETS, GUTTER, WALL SHEETS, WALL GIRTS, ROOF PURLINS, EAVE PURLINS, KNEE AND APEX BRACES SPECIFICATIONS AND LOCATIONS ARE INDICATIVE ONLY. REFER TO ENGINEERING PLANS FOR ACTUAL CONFIGURATION.

## 35 Fixing of Openings

**NOTE: BUILDING CONFIGURATION IS INDICATIVE ONLY. REFER TO ENGINEERING PLANS FOR ACTUAL BUILDING CONFIGURATION AND SPECIFICATIONS.**

***Refer to Manufacturer's Specifications and Installation Procedures to all openings as required.***

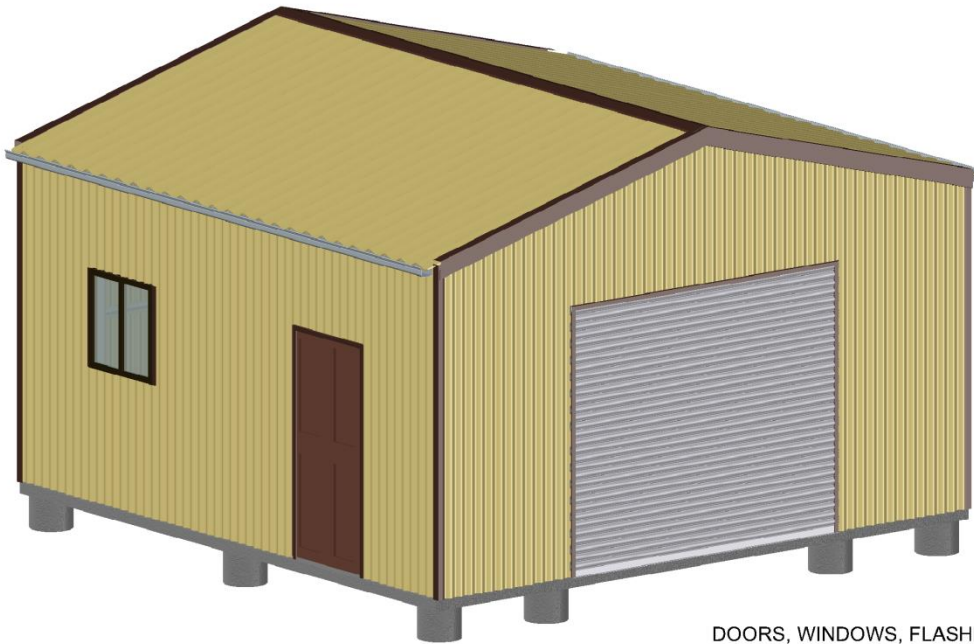

DOORS, WINDOWS, FLASHING, ROOF SHEETS, GUTTER, WALL SHEETS, WALL GIRTS, ROOF PURLINS, EAVE PURLINS, KNEE AND APEX BRACES SPECIFICATIONS AND LOCATIONS ARE INDICATIVE ONLY. REFER TO ENGINEERING PLANS FOR ACTUAL CONFIGURATION.

FIXING OF DOORS AND WINDOWS

### 36 Fixing of Downpipe

Remove plastic coating from the downpipe. Fix downpipes to nozzle with pop rivets or wall screws whichever is applicable. The larger end of the downpipe is attached to the nozzle to allow for a correct water flow. A downpipe bracket called “astragal” can be formed by trimming and folding to suit the required shape. Alternately, a wall screw can be fixed from the inside of the building through the bottom sidewall girt into the downpipe.

#### ATTACHING THE DOWNPIPE

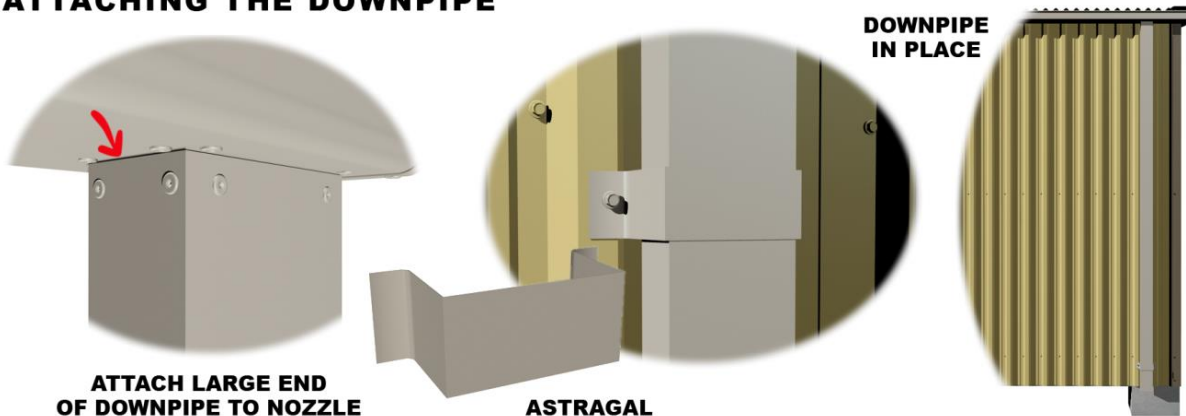

### 37 Installation of Personal Access Door

**NOTE:** Installation of Personal Access Door Jamb(s) and Header(s) should occur **AFTER** the wall sheeting is completed and **BEFORE** flashings are fixed. The pre-installed side wall sheets will need to be cut to suit the personal access door opening location and size.

**NOTE:** Installation of Personal Access Door(s) and Associated Parts should occur **after** the flashings and downpipes have been fixed.

**POSITION** – Personal Access Door(s) can be positioned anywhere between two intermediate frames on the sidewall and between endwall mullions on the endwall. Any wall strap bracing affected by the position of the opening will need to be adjusted or moved to satisfy structural requirements.

**OPENING SIZE** – Refer to Manufacturer’s Specifications on how to determine the Opening Size. The PA Door size is normally equal to the opening size. Once the opening size is determined, mark the position of the door jambs on the slab and mark the width on the sidewall girts. Once marked, wall girts are to be cut to suit the PA door opening width.

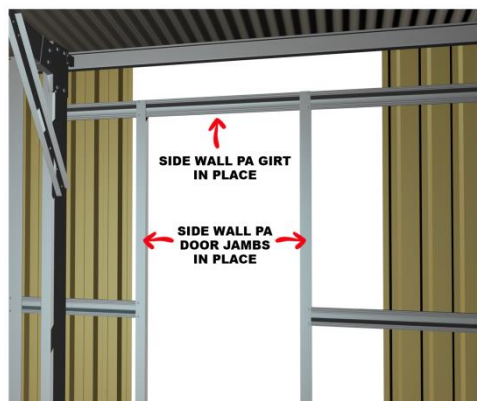

**PERSONAL ACCESS DOOR JAMB** – Depending on the height of the personal access door jamb, the notched top part of the jamb can either be attached to the next wall girt or to the eave purlin whichever is applicable. The door jambs are supplied in stock lengths and has to be cut and notched out to suit the next support above the door. The web part of the jamb has to be notched out and the 2 upright legs attached to two sides of either the wall girt or the eave purlin whichever is applicable. Ensure that the longer leg of the jamb faces inside the building. Ensure that the jambs are plumb prior to fixing the base cleat at the bottom of the personal access door jamb and masonry anchor to the slab. Fit both Left Hand and Right Hand personal access door jambs as per marked position.



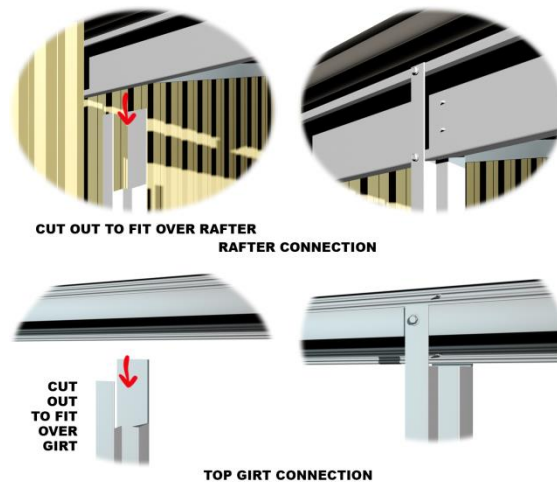

**TIP:** There are two types of Personal Access door Jamb, rebated and non-rebated. The installation procedures for both types are exactly the same.

**PERSONAL ACCESS DOOR HEADER** – The height of the door header is equivalent to the door height opening required as previously determined. Measure and mark the height of the PA door header to the two sides of the door jambs already in place. The total length of the header is equal to the door width plus twice the door jamb width. Mark on each side of the header a line to match the opening width. Notch out the web of the jamb as marked leaving the two legs. Fit and insert the Personal Door Header on each side of the jamb and fasten the two legs to the jambs with framing screws. Ensure that the open side of the door header faces up.

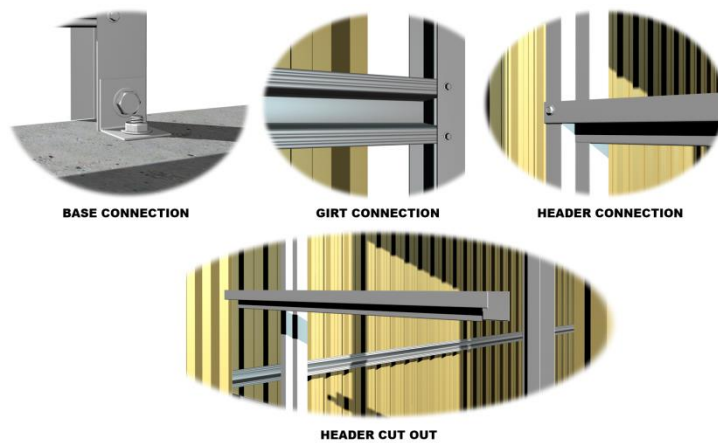

**TRIM** – After the opening has been permanently fixed, complete the trims and flashings around the perimeter of the opening.

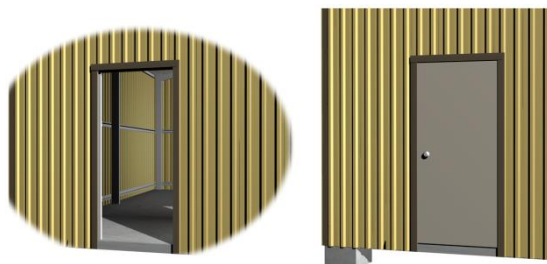



**PRE-HUNG PERSONAL ACCESS DOOR JAMB** – Depending on the height of the personal access door, the notched top part of the jamb can either be attached to the next wall girt or to the eave purlin whichever is applicable. The door jambs are supplied in stock lengths and have to be cut and notched out to suit the next support above the door. The web part of the jamb has to be notched out and the 2 upright legs attached to two sides of either the wall girt or the eave purlin whichever is applicable. Ensure that the longer leg of the jamb faces inside the building. Ensure that the jambs are plumb prior to fixing the base cleat at the bottom of the personal access door jamb and masonry anchor to the slab footing. Fit both Left Hand and Right Hand personal access door jambs as per marked position.

**PRE-HUNG PERSONAL ACCESS DOOR** – Refer to Manufacturer’s Specifications and Installation Procedure for the Installation of the Pre-Hung Personal Access Door and Associated Parts.

## 38 Completion

Make a final check of the completed structure.

Ensure that all base cleats have been tightened down firmly.

Ensure that all bolts are complete and tightened.

Check that the roof and wall screws are complete and tightened.

Brush the completed structure down including the roof with a soft hair broom to remove any swarf (metal dust and fillings caused by an angle grinder).

Hose down the concrete slab to remove any particles, screws and rivets for safety.

**STAND BACK AND CONGRATULATE YOURSELF ON A JOB WELL DONE!**

TIP: DON'T FORGET TO PUT YOUR DISTRIBUTORSHIP STICKER ON
--