

Care & Storage.....	1
Tools Required.....	2
Shed Terminology.....	3
Slab Check.....	4
Step 1 - Marking Out The Building On The Slab.....	5
Step 2 - Unpacking Your Shed Kit.....	6
Step 3 - Assembling Rafters.....	7
Step 4 - Columns, Haunch Brackets, Base Brackets.....	8
Step 5 - Assembling Wall Frames.....	9
Step 6 - Standing The Walls.....	14
Step 7 - Installing End Rafter.....	15
Step 8 - Installing End Wall Mullion.....	16
Step 9 - Installing Remaining Rafters.....	19
Step 10 - Fixing Roof Purlins.....	19
Step 11 - End Wall Roller Door/s Columns.....	20
Step 12 - End Wall Roller Door/s Header.....	21
Step 13 - End Wall Girts.....	22
Step 14 - Fixing Knee & Apex Braces.....	22
Step 15 - Fixing Fly Bracing.....	23
Step 16 - Side Wall Roller Doors.....	23
Step 17 - PA (Personal Access) Doors.....	24
Step 18 - Windows.....	24
Step 19 - Side Wall Sheeting.....	25
Step 20 - End Wall Sheeting.....	26
Step 21 - Gutters.....	27
Step 22 - Roofing Sheeting.....	28
Step 23 - Flashings.....	29
Step 24 - Downpipes.....	31
Build Complete.....	32

Thank you for purchasing a building from Best Sheds. We are a family business who pride ourselves on price, quality and customer service with a combined 65+ years experience in the shed industry from which we have the passion, knowledge and expertise to help achieve your desired outcome.

We hope you enjoy erecting your new building and gain satisfaction from building it yourself and in the process saving some money.

Please check that you have adhered to all relevant local / state authority requirements before beginning any work on site.

Any sub-contractors need to be licensed and have all necessary insurances in place.

Please refer to your plans for all connection details and measurements. If you have any queries please call your salesperson.

CARE & STORAGE

Zinc-coated, ZINCALUME, ®, Zinc/aluminium alloy coated steel and COLOURMASTER™ pre-painted steel roofing and walling products are normally delivered to the building site in strapped bundles.

If not required for immediate use, sheets or bundles should be neatly stacked clear of the ground. If left in the open, they should be protected from rain and moisture with tarpaulins or similar covers. On no account should steel sheeting be allowed to get wet while still bundled or nested in stacks. Rain and condensation are easily drawn between the surfaces of nested sheets by capillary action or driven in by wind action and, as this trapped moisture cannot evaporate normally, it can cause deterioration of the coating which may lead to a reduced life expectancy or poor appearance (wet storage stain).

If packs become wet the sheets should be separated without delay. The sheets should then be stacked so that air circulation completes the drying process. Wet storage stain can occur from condensation alone – even in dry weather. Therefore, keep the product dry to reduce the risks of water damage and keep storage time to a minimum.

Roller doors are very fragile and need to be treated with care to ensure no damage is done to the door whilst the door is being stored or installed.

Below is a guideline on what to do and what NOT to do with your new roller door and associated products:

DO NOT do the following to your roller door:

- Put the roller door on the ground without packaging under the door
- Place or rest the roller door over any edge of your concrete slab
- Use the roller door as a workbench
- Sit on the roller door
- Put any items at all on the roller door
- Roll the roller door on the ground
- Put the roller door on timber gluts
- Do not drop the roller door

TOOLS REQUIRED

This manual is only a guide to help you build your shed. Please follow all WHS (Work Health & Safety) guidelines. If you are not experienced in building or do not feel confident in attempting such works, it is recommended you contact a licensed builder to complete the installation of your shed.

Before lifting walls and inserting hold down bolts, ensure that concrete has been correctly cured and reached its minimum strength as specified in the engineer's plans.

What tools will you need?

- Hammer
- Tape measures
- Clamps
- Tin snips
- Socket set
- Roofing silicone and a caulking gun
- Rivet Gun
- Utility knife
- Multigrips
- Permanent marker, builders pencil
- Chalk line
- String line
- Spirit level
- Square
- Screw drivers
- Tek screw gun with appropriate drive bits
- Electric drill, metal drill bits
- Nibbler (alternatively tin snips)
- Grinder
- Hammer drill
- Extension leads
- Ladders
- Scissor lift/s (on larger jobs)
- Nail bag
- Personal Safety Equipment
- Ear Muffs
- Safety goggles
- Gloves
- Highly visible clothing
- Steel capped boots
- Sunscreen

NOT ALL DRILLS ARE EQUAL

It is recommended that clutched screwdrivers are used over a cordless impact driver as the impact drivers place excessive force through the screw, often drilling at a much higher RPM compared to a clutched screwdriver. The excessive stress can cause the heads to snap off the screw, especially on the framing screws.

CAUTION

Extreme caution is required when handling and working with steel. Take your time when moving the steel. Always wear safety goggles. Get an assistant to help you to ensure your safety and the safety of others on site.

Let's get to work...

****Note – Ensure all wall sheeting and girts have been counted and accounted for to ensure you are aware of the full amounts supplied for the construction and the location for the girts and sheeting, so you do not cut the sheeting or girts for the wrong locations. If you are unsure of amounts, parts and locations please call your salesperson for assistance.**

SHED TERMINOLOGY

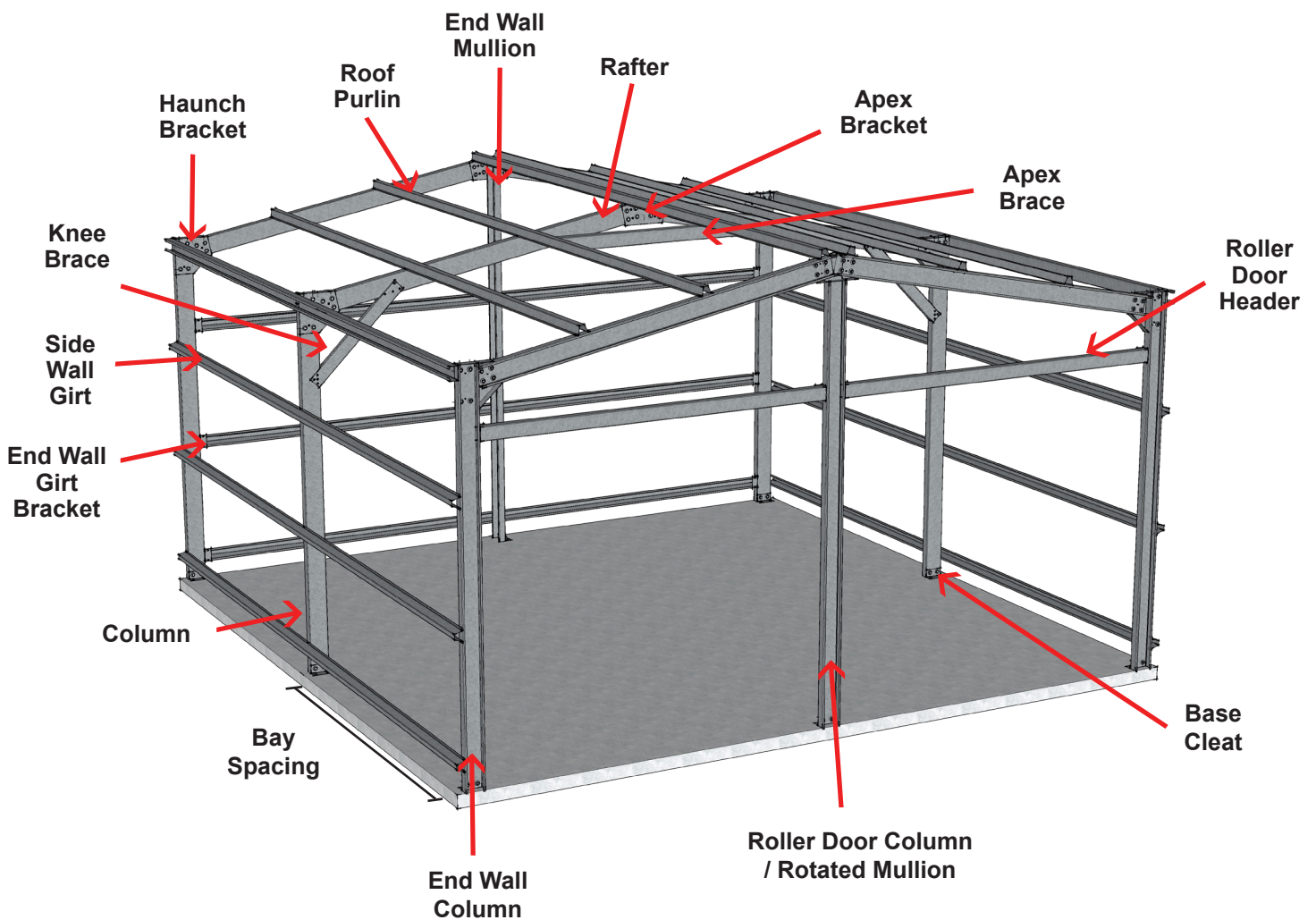

SLAB CHECK

Your slab is already poured to the engineer's specifications provided on your plans.

The first thing that we need to do is to measure that the slabs overall dimensions are correct and that the slab is square.

The overall dimensions for your slab will be the same as the shed size you ordered.
For example: if you order a 7.0m x 10.5m building, then your slab will be 7.0m x 10.5m.

To check the slab is square you need to check that the diagonals of the slab are equal. If they are equal then the building is square.

For the purpose of the manual we will assume that the slab is square and the overall measurements are correct.

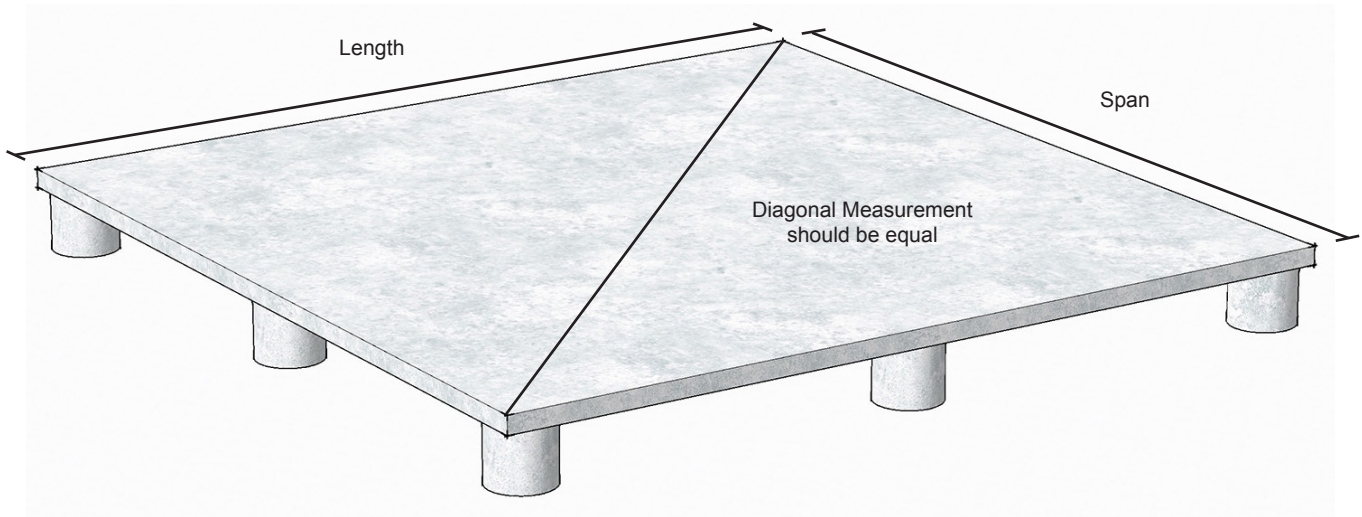

STEP 1 Marking out the building on the slab

Before bringing any materials onto the foundation, it is best to firstly mark out for your column locations. We want to flick a chalk line marking the inside of the columns on both sides of the building. Later, when we stand our walls, we will use these chalk lines to ensure our walls are straight and in the correct location prior to fixing the walls to the foundations.

To determine where to mark your chalk lines, we need to refer to your engineering drawings.

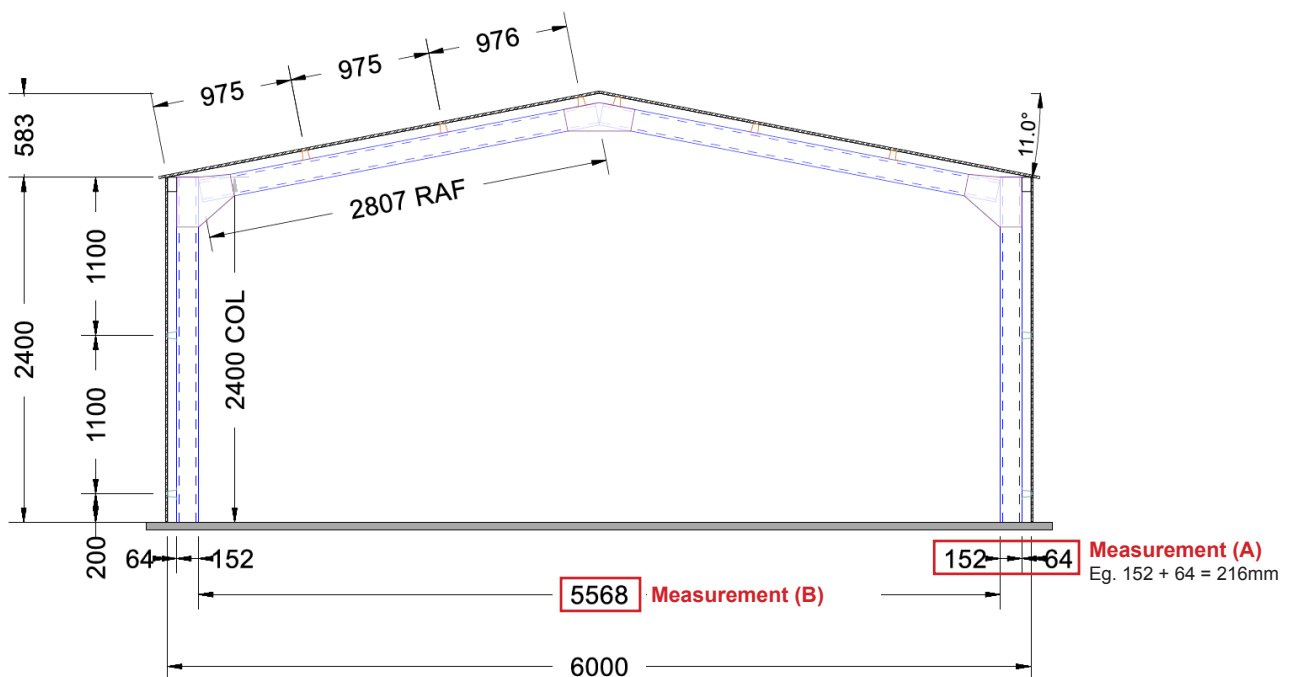

On your engineering drawings, you need to locate the page showing the intermediate portal frame of the building. This drawing will show you the dimensions from the outside of the slab to the inside of the column (column width + wall girth height) (**Measurement A**).

Mark this dimension onto your foundation on all four corners of the building. Ensure you are measuring off the correct side of the foundation (side wall).

Now flick a chalk line between these marks, on both sides of the building.

Measure the distance between the two chalk lines and double check this measurement matches the engineering drawings (**Measurement B**). This measurement will be used to make our rafters in step 3. This measurement will be known as our 'long point rafter length'.

Now mark the 'frame overall dimension' down both side walls of your building (the gutter walls) and flick a chalk line at this location. This is the inside of the columns.

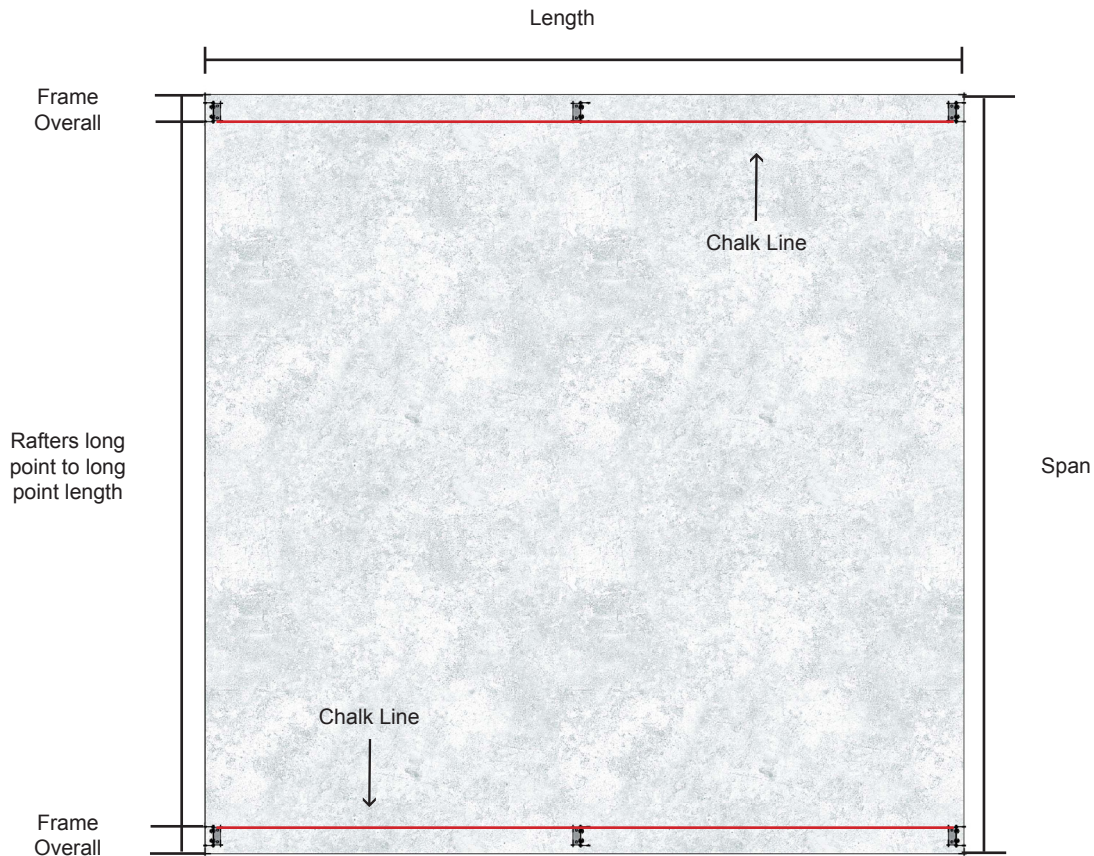

The distance between the lines you have now marked is the long point to long point of the rafters, which you will need in step 3.

STEP 2 Unpacking your shed kit

Time now to unpack your shed kit, laying the materials out so that we can access various components of the kit as we need them throughout the build. Care must be taken when handling all components of the kit, sheeting and flashings are easily scratched if incorrectly handled. Extreme care must be taken when handling and storing roller doors. All coloured materials must be placed onto appropriate sponge type packaging to prevent any damage.

Do not ever sit or walk on your roller door. Always ensure there is thick packaging under the door preventing it being damaged from sharp objects on the ground like rocks.

When laying out your materials out be sure to consider the possibility of wind and it blowing away and damaging any loose items.

STEP 3 Assembling Rafters

Lay 2 rafters out onto the slab with the bottom of the rafters touching at the apex. Using the apex bracket as a rough guide to set the pitch of the rafters. (Check the member schedule to see if your building has single or back to back rafters).

Now measure long point to long point of the rafters and adjust until the measurement is the same as in the previous step.

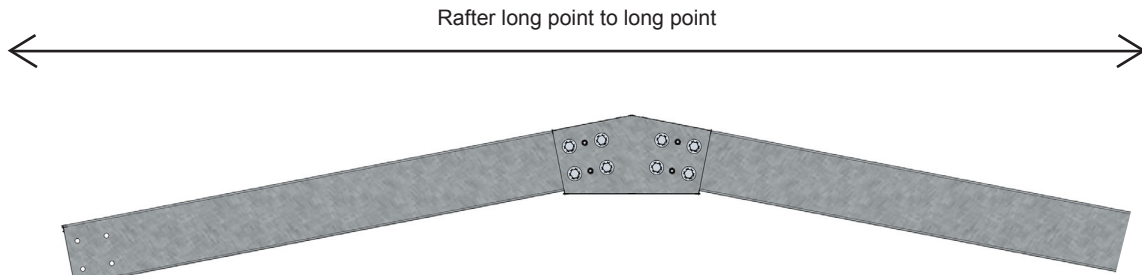

Put the apex bracket in place, check that all of the punching are in line and that the rafters are still touching. Put in 2 'tek' screws through the apex bracket in to the rafters (1 screw per rafter) as shown in drawing 2.01 ('teks' screw first location).

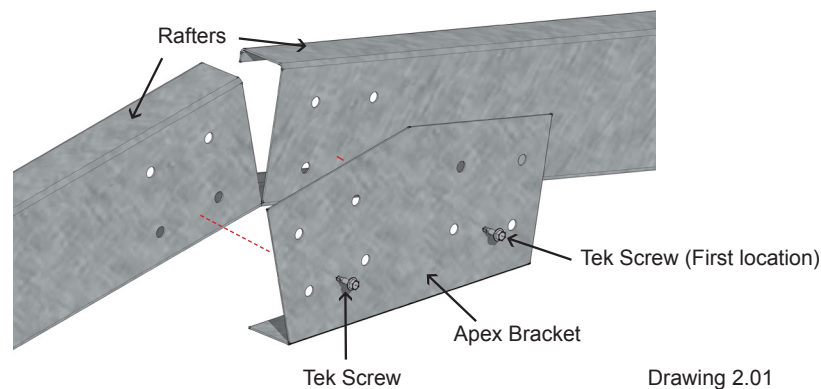

Put 2 more 'tek' screws through the apex bracket into the rafter ('tek' screw second location) to lock the rafters at the correct overall width and therefore correct pitch. Now put all bolts in as per engineering details.

If apex brace are required in your building, bolt these to the rafters now in accordance with the engineering details.

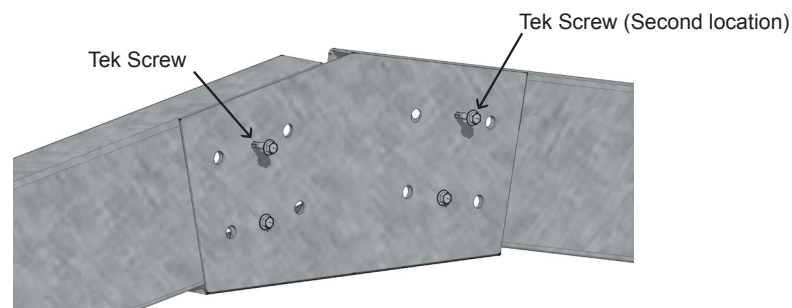

TIP: Now is a good time to mark your roof purlins onto the rafters (to save doing it from a ladder later on in the build).

It's also a good idea to put a temporary screw in the rafter at the base of all purlins. Doing this prevents the purlins from sliding down the rafters while screwing them off. Roof purlin spacing can be found in the member schedule on your engineering plans.

STEP 4 Columns, Haunch Brackets, Base Brackets

Place the columns out on the slab, at approximate bay spacing's. Bolt the haunch bracket and base bracket onto the column in accordance with engineering details.

(Check the member schedule to see if your building has single or back to back columns)

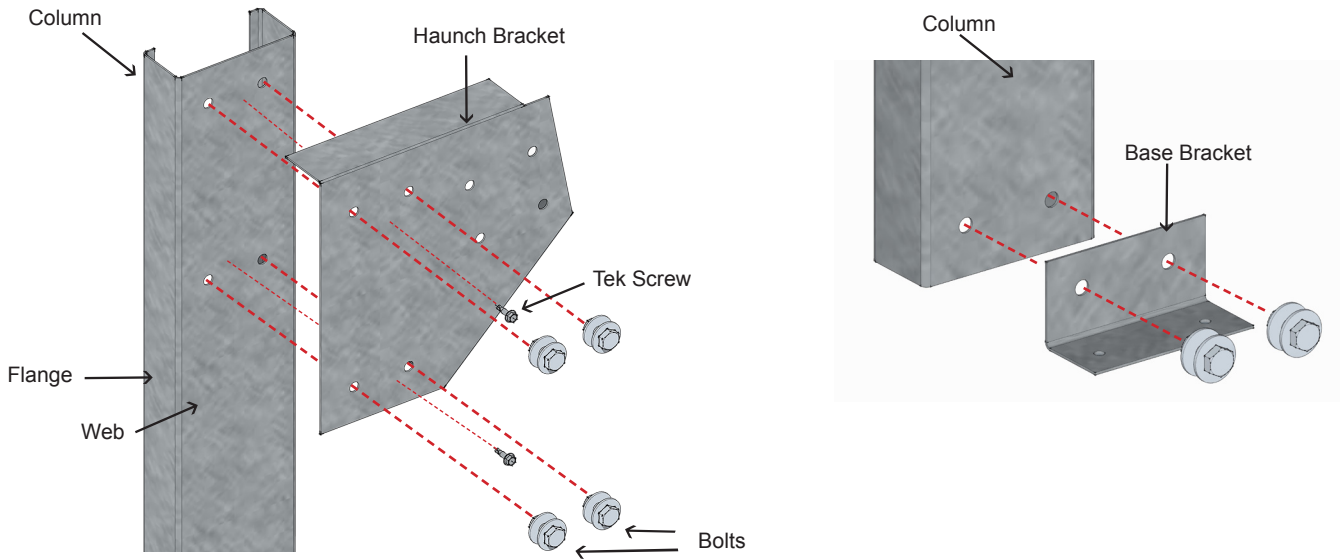

The end portal frames (front and back) need to have the webs of the c section facing into the building. This is so that a roller door may be attached to the column, and for aesthetics. Unless open gable walls. Refer to floor plan. Intermediate portals can face either way, however for aesthetics the webs are generally faced towards the prominent opening, i.e. roller doors.

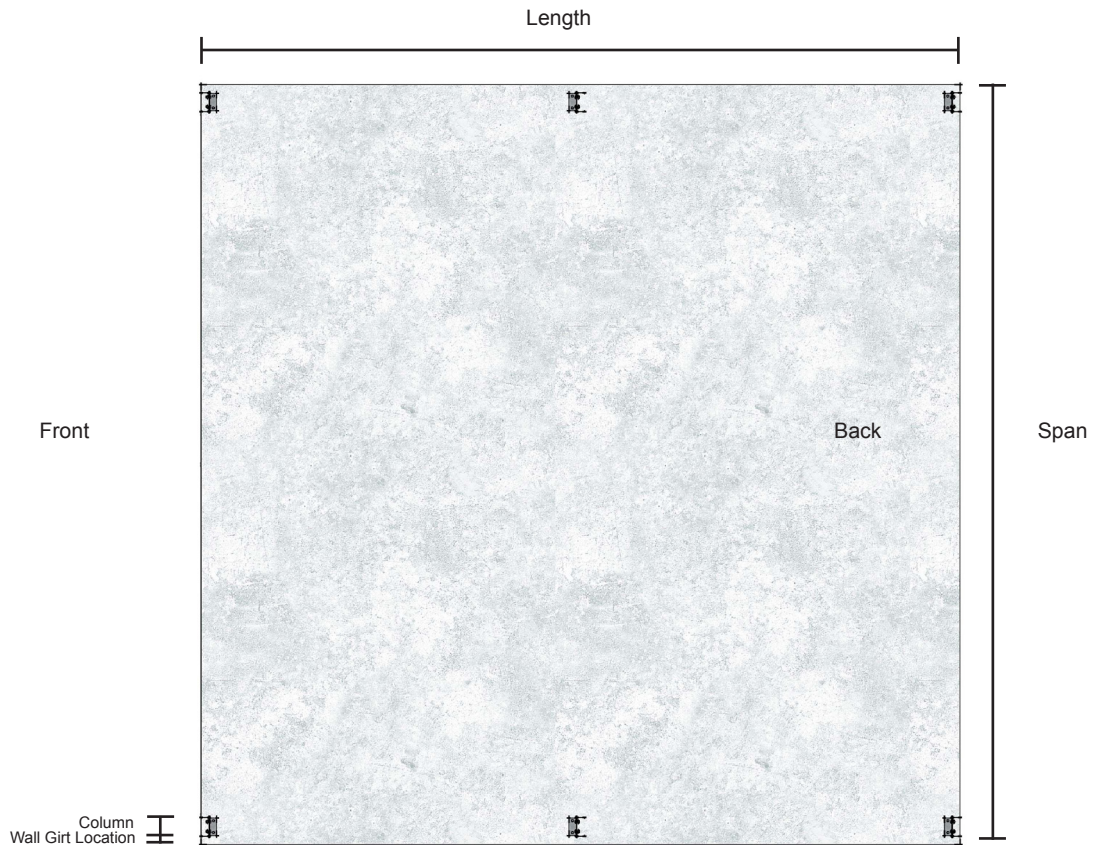

STEP 5 Assembling Wall Frames

Assembling the wall frames varies slightly depending on the wall girt size of your building.

If your girts are TH64XX then continue reading step 5.1

If your wall girts are TH120XX then skip to step 5.2 (pg12)

5.1 Top hat 64mm Option

You need to attach the C100 eave purlin to the top of the columns. The C100 eave purlin will be flush to the top of the column. The C100 eave purlin is 64mm deep, making it the same dimension as the TH64 wall girts.

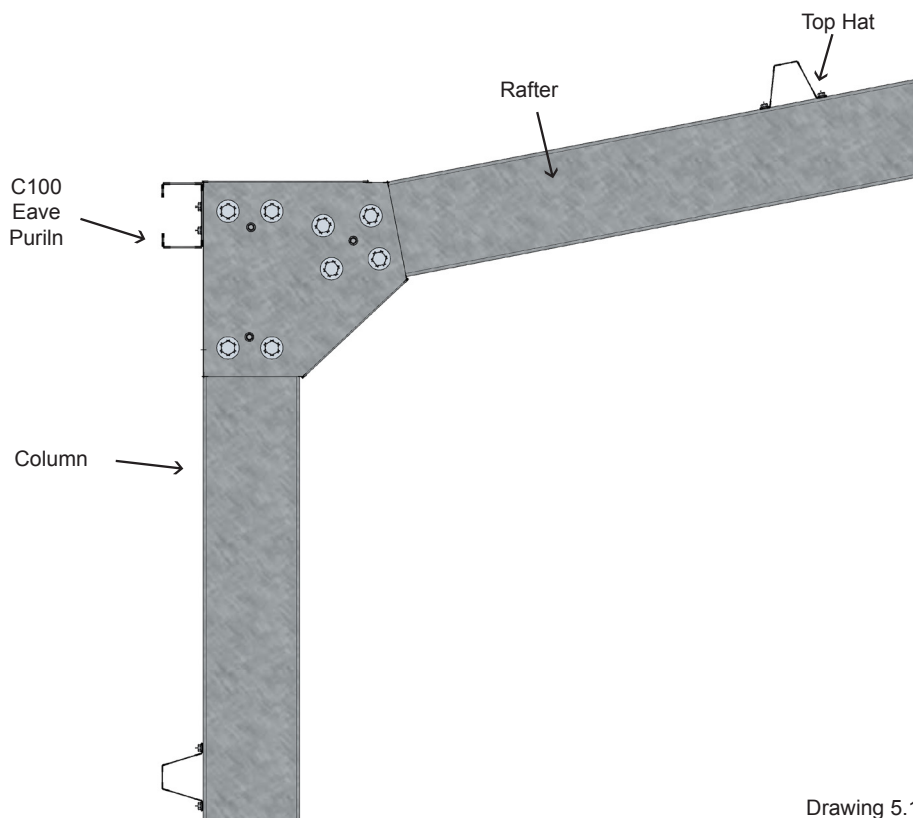

Drawing 5.1

Your columns are already laid out on the slab, with the haunch and base brackets bolted on. Now lay out the C100 eave beams down the centre of the slab (as per drawing 5.2).

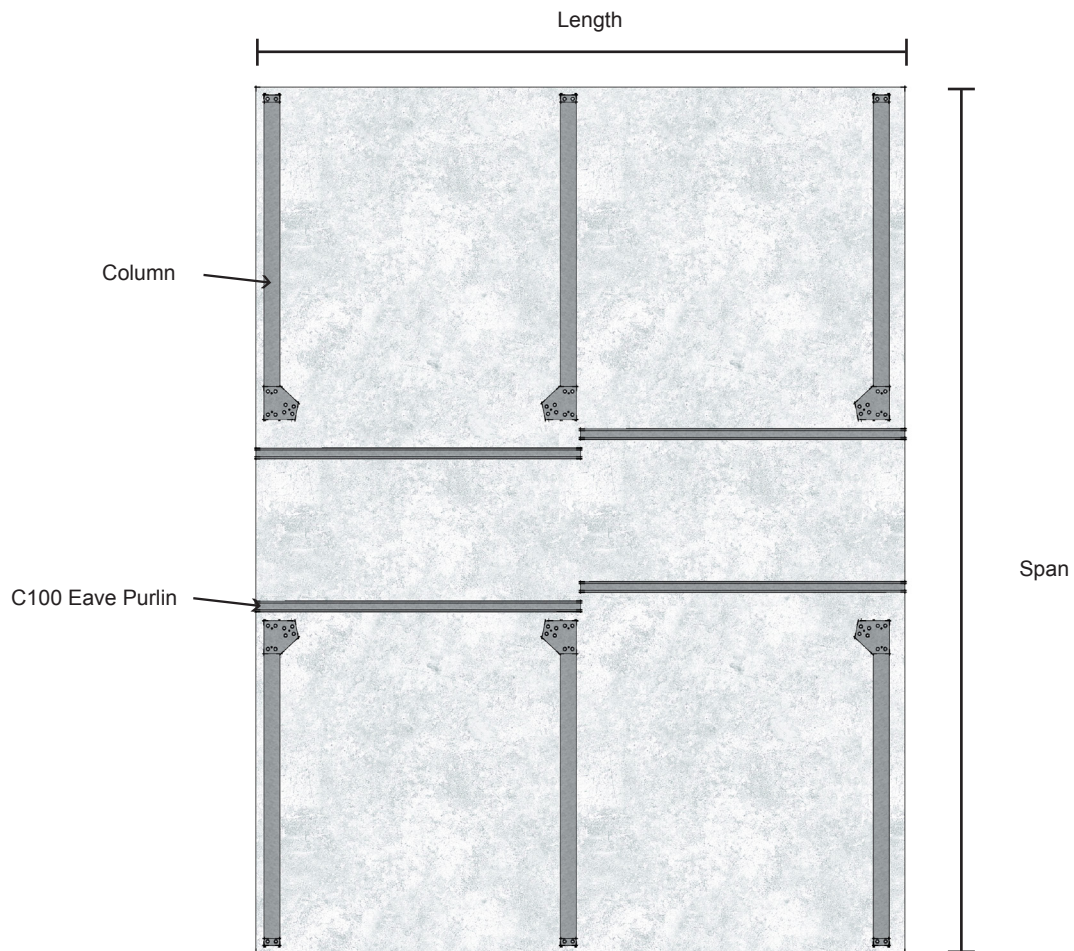

Drawing 5.2

Bay spacing needs to be determined to know the exact location of your columns. The C100 eave purlins may need to be cut down to the same length as your bay spacing. (As specified in your engineers plans). Bay spacing on the front and back columns will run to the outside edge of the column.

On intermediate columns the bay spacing will be in the centre of the column. As per drawing 5.3

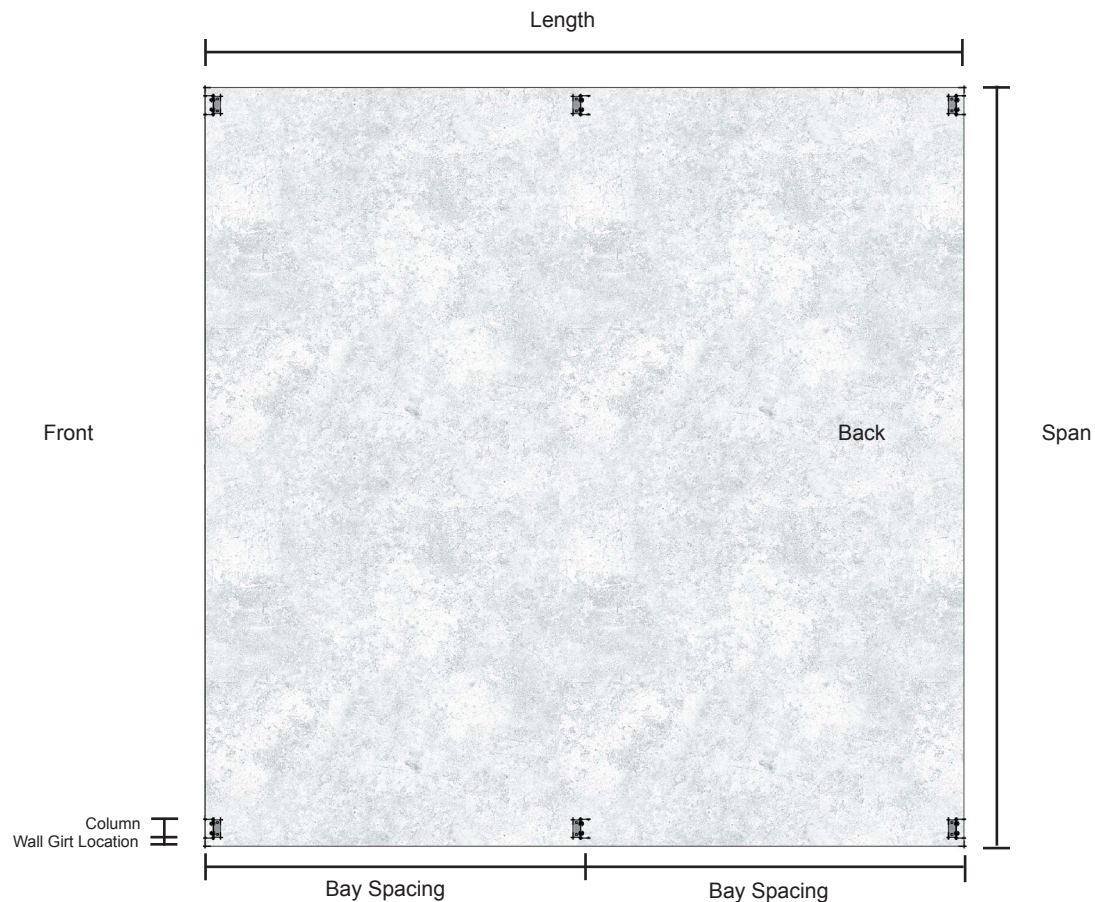

Drawing 5.3

Screw the C100 eave purlin flush to the top of the columns. The number of screws in accordance with engineering details.

Mark the wall girt spacing onto the columns. The lowest girt is located 200mm from the bottom of the column to the top side of the wall girt.

The remaining girts are spaced evenly. Maximum wall girt spacing according to engineering details (member schedule). (Please note – Roller doors that are to be installed into the gutter side wall and not the gable end walls will need the wall girts to be cut out of the supplied consolidated Top Hats. Full length wall girt Top Hats have NOT been supplied for these roller doors, so the full-length wall girt top hats are NOT to be installed and cut out for the roller door or you will run out of Top Hats for the roof purlins)

Now lay out the wall girts and screw them into place using one screw at each column connection point. Ensure that the columns are all parallel, and bay spacing measurements are as per drawing 5.3.

Run a string line at the base of all columns, and check the wall frame is square (check diagonals). Now finish installing all frame screws at the wall girt to column connection in accordance with the engineering details.

5.2 Top hat 120mm Option

Now attach the TH120 eave purlin to the top of the columns. The TH120 eave purlin will be flush to the top of the column. A TH64075 is then attached on the top side of the TH120 eave purlin, in order to provide a fixing location for the end of the roof sheets. See drawing 5.4

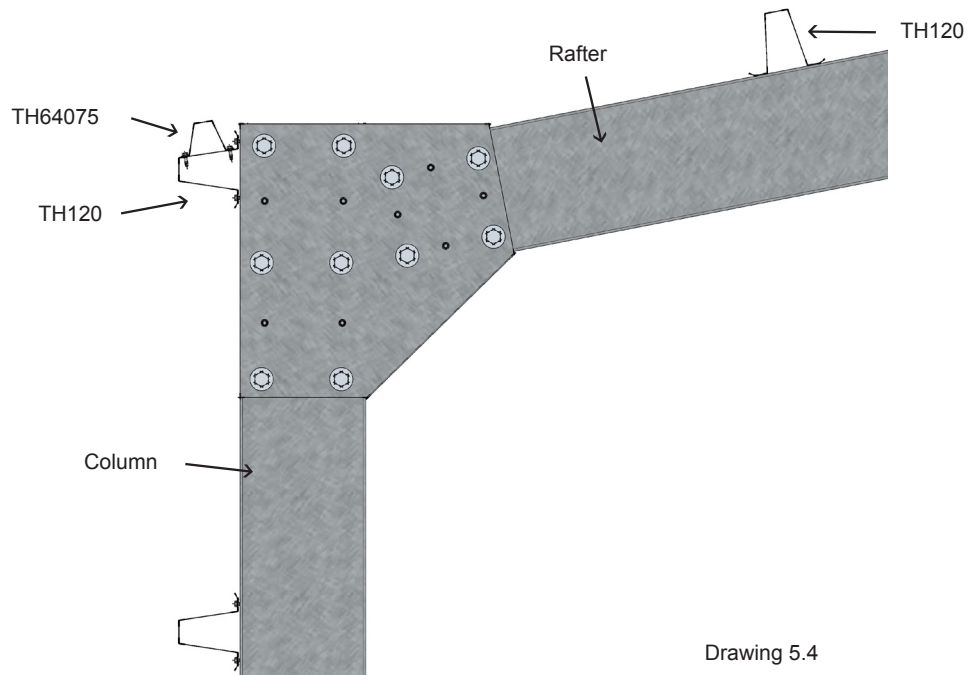

Your columns are already laid out on the slab with the haunch and base brackets bolted on. Now lay out the TH120 eave beams down the centre of the slab (as drawing 5.5).

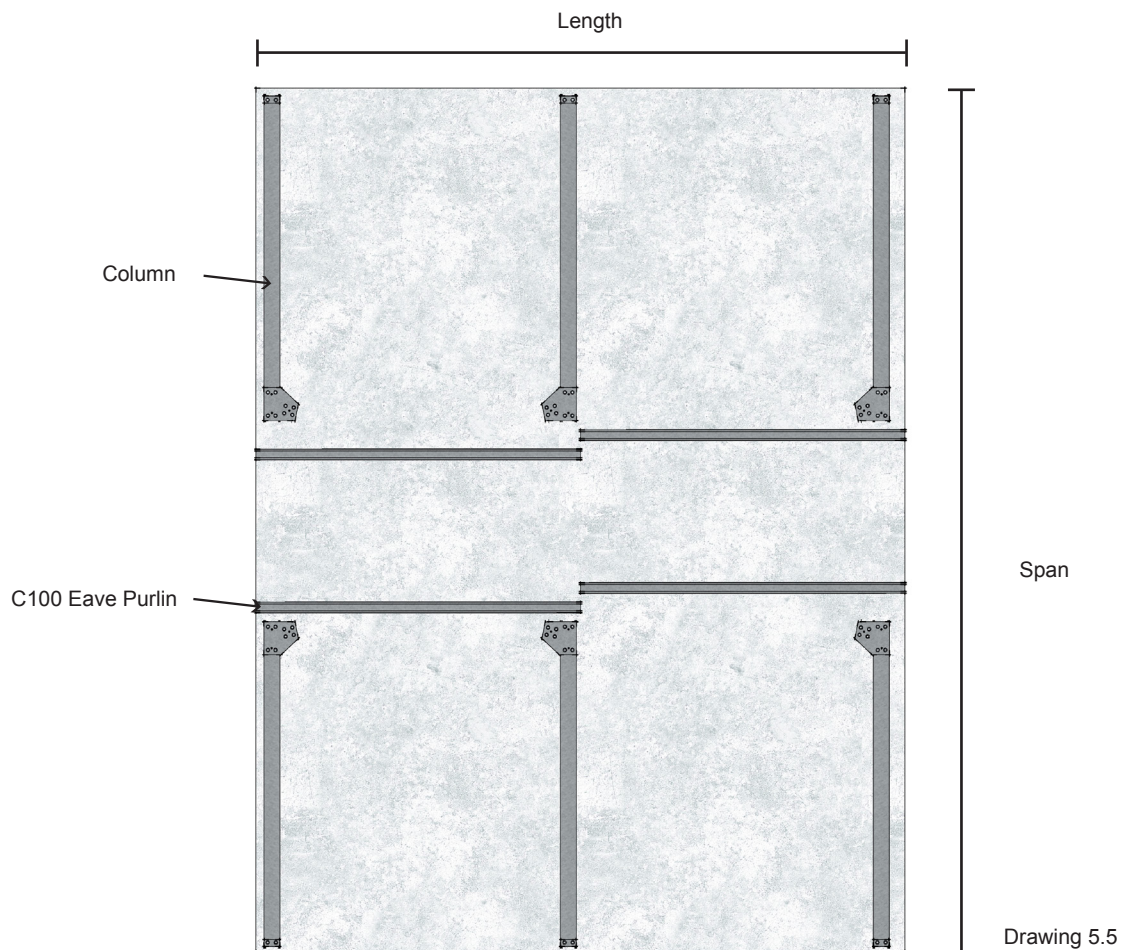

Bay spacing needs to be determined to know the exact location of your columns. Check your engineering plans to get your bay spacing. Bay spacing on the front and back columns will run to the outside edge of the column.

On intermediate columns the bay spacing will be in the centre of the column. As per drawing 5.6

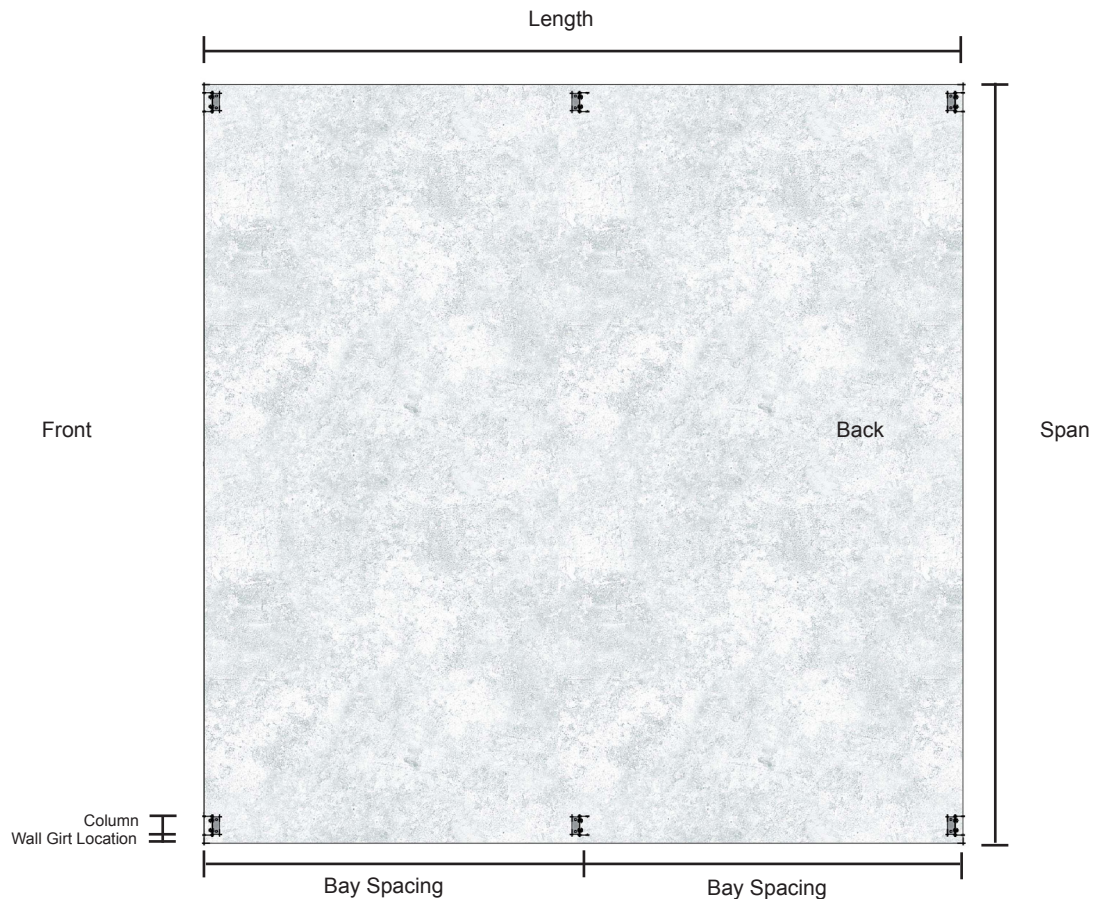

Drawing 5.6

Screw the TH120 eave purlin flush to the top of the columns. The number of screws in accordance with engineering details.

Mark the wall girt spacing onto the columns. The lowest girt is located 200mm from the bottom of the column to the top side of the wall girt.

The remaining girts are spaced evenly. Maximum wall girt spacing according to engineering details (member schedule). (Please note – Roller doors that are to be installed into the gutter side wall and not the gable end walls will need the wall girts to be cut out of the supplied consolidated Top Hats. Full length wall girt Top Hats have NOT been supplied for these roller doors, so the full-length wall girt top hats are NOT to be installed and cut out for the roller door or you will run out of Top Hats for the roof purlins)

Now lay out the wall girts and screw them into place using one screw at each column connection point. Ensure that the columns are all parallel, and bay spacing measurements are as per drawing 5.3.

Run a string line at the base of all columns, and check the wall frame is square (check diagonals). Now finish installing all frame screws at the wall girt to column connection in accordance with the engineering details.

Now screw the TH64075 into position on top of the TH120 eave purlin, as per drawing 5.4. Check your engineering plans to see if any side wall strap bracing is required. If so, install strap bracing onto the wall frame.

STEP 6 Standing The Walls

Before lifting the wall ensure you have the following ready to secure the frame to the foundations:

- Dyna-bolts,
- Hammer drill (with appropriate drill bit),
- Hammer,
- Socket (or Rattle Gun) and
- Temporary Props, Bracing and Ropes.

Ensure the end columns are flush with the ends of the slab.

Appropriate tie down points, ropes and props are required to assist holding the wall vertical until you have all hold down bolts in and rafters secured in place. The larger the shed the more ropes and props you will need.

Ensure you have enough ropes and props to comfortably hold the wall against any wind that may occur.

Do not attempt to lift walls on a windy day or where strong winds are predicted.

Once you have all of your ropes and props in position you can stand the wall. The size of the building will determine how many assistants or the size of crane required to lift the wall. If using a crane, a spreader bar is required along with significant lengths of chain, so it does not damage any part of the wall when lifting.

Once the wall is vertical and temporary ropes and props are secured, adjust the wall so that the first and last columns are flush to the concrete slab edge. Then move the inside flange of the columns to the line marked on the concrete slab back in step 1. Ensure the columns are aligned with the chalk line, (not twisted) and are plumb (adjust props if necessary).

Now drill appropriate size hole with a masonry bit (not included in kit) through the base bracket into the concrete (hold down / Dyna-bolt size shown on the engineer's plan). Hammer in hold down bolts and tighten.

Repeat step 5 for other side wall.

First Frame Standing (With no gutter side wall roller doors)

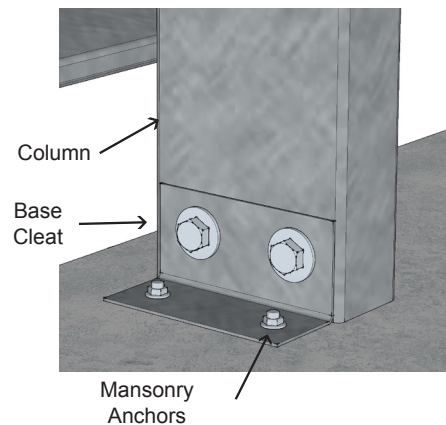
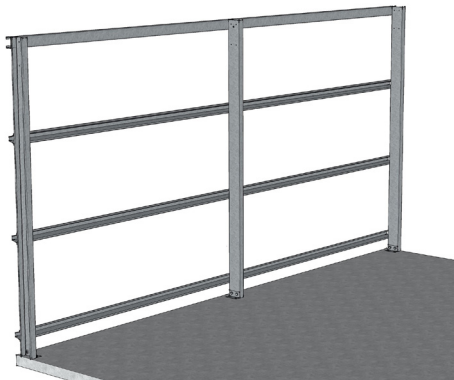

First Frame Standing (With gutter side wall roller doors)

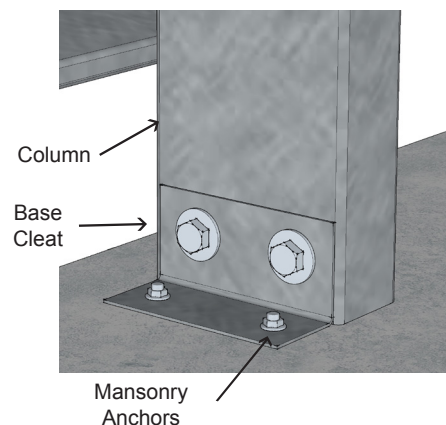
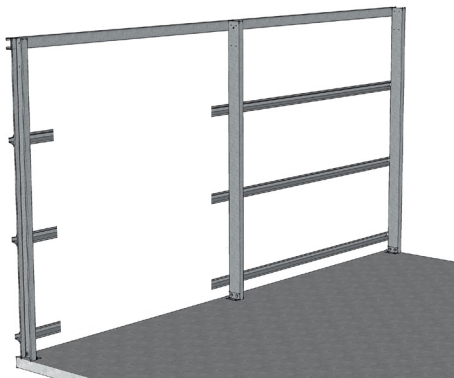

STEP 7 Installing End Rafter

The size of your building will determine whether you need a crane to lift rafters into place, and also whether you need scissor lift/s, mobile scaffolding to install rafters, roof battens, roof sheeting etc. Follow OHS (Occupational Health & Safety) guidelines for working safely on site, in particular working at heights.

Starting at the back wall of the building, carefully lift the previously assembled rafters (step 2) up onto haunch brackets that are already bolted onto columns (step 3). Use a clamp to hold the rafter in position.

Align bolt holes and put 1 x temporary 'tek' screw through the haunch bracket into the rafter on each side of the building.

Now install all frame bolts to engineer's details. Only do them up finger tight for the moment.

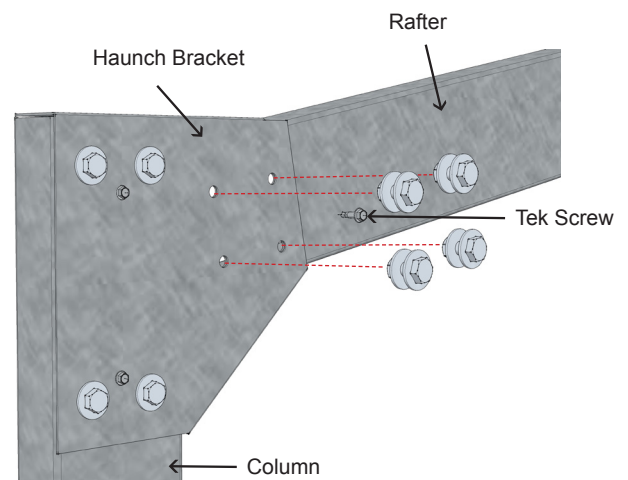
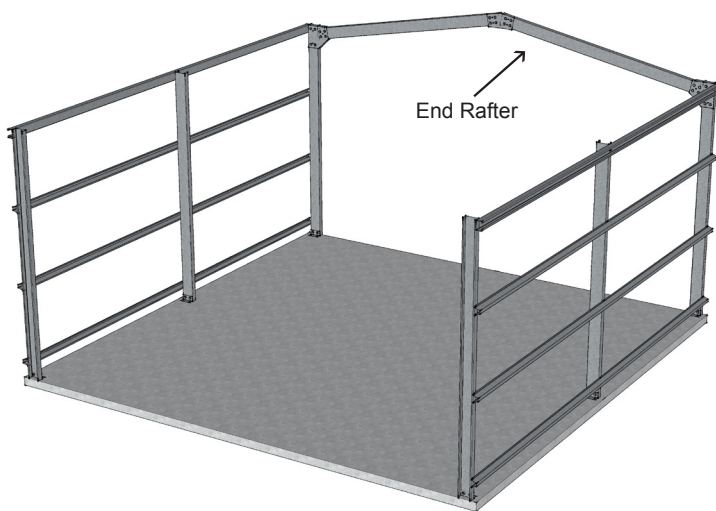

NOTE: Ensure that the lifting device used to install the rafter is still in place to prevent the rafter from rolling and possibly tearing the brackets. It is also important to ensure that the weight of the rafters is on the haunch brackets and the lifting device is only balancing the rafters.

Using a spirit level, re-check the plumb of the 2 columns that the rafter has just been attached to. Adjust props / ropes as necessary. Now tighten the haunch bracket to rafter frame bolts.

STEP 8 Installing End Wall Mullion

Check your engineering plans for spacing and number of end wall mullions.

Mark out end wall mullion positions onto the slab. End wall Mullions will be perpendicular to the rafters. End wall mullions can face either way, for aesthetics face the flat face (web) of the C section towards any side wall openings.

Depending on your building span you might have,

1. No end wall mullions
2. One end wall mullion in each end wall, this will be right in the centre on the apex bracket. This option may require apex bracket bolts being removed and drilled through the mullion (on Top hat 120 option)
3. Two or more end wall mullions in each end wall, in this case mullions will be located along each rafter

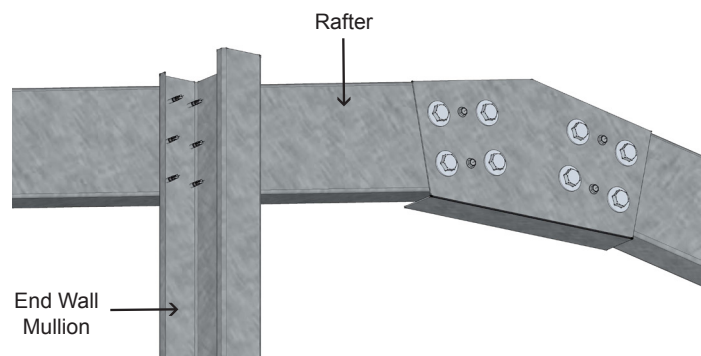
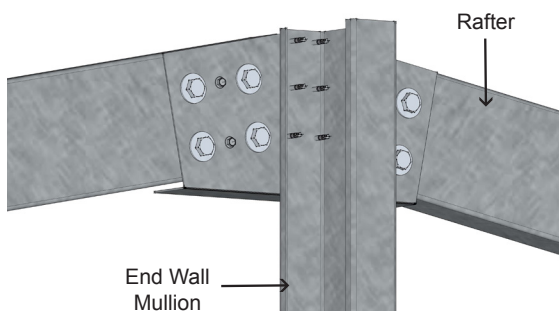
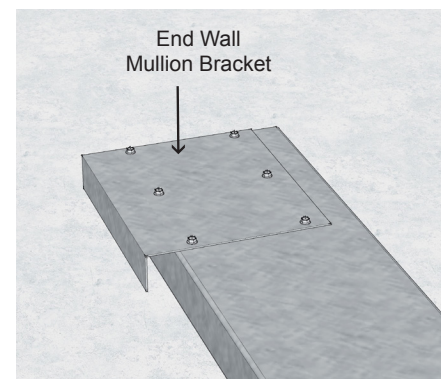
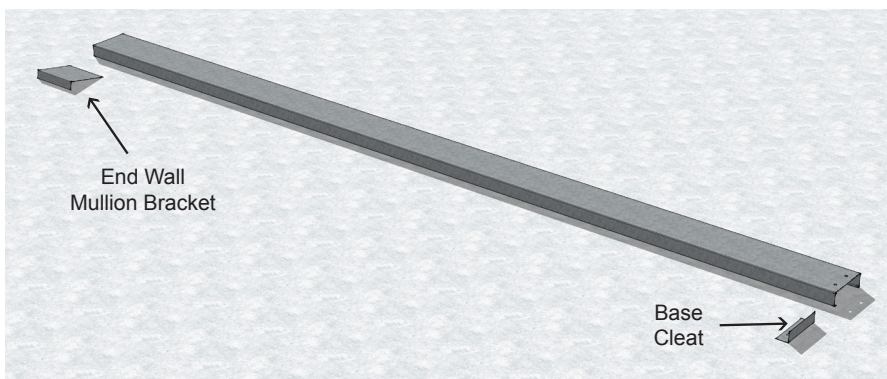

Drawing 7.1

End wall mullions are offset end wall girt thickness from the slab edge (Check end wall girt size from engineer's plans).

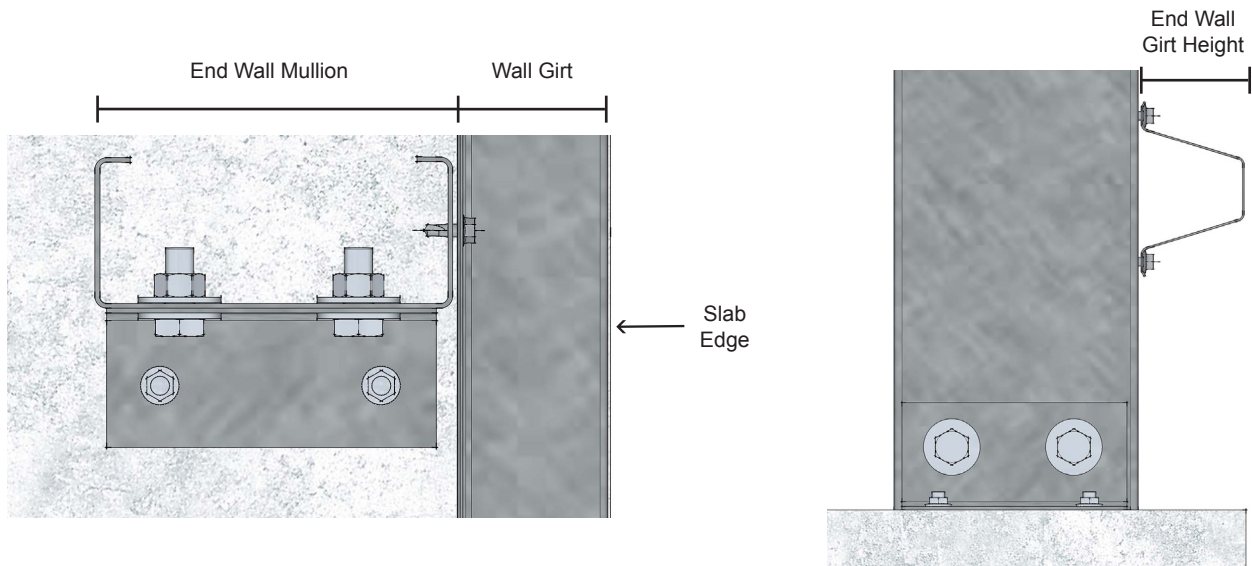

Locate your end wall mullions and bolt the base brackets on to pre-punched holes (to engineer's drawings).

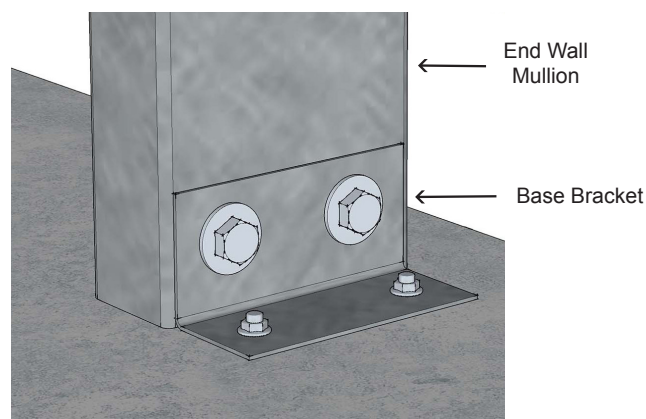

Stand end wall mullion in position and roughly plumb. Check height of mullion to the top of the rafters and if necessary, mark and cut the mullion to ensure it will not interfere with roof sheeting.

Check your end wall girt size (same as start of step 4) and determine whether you have 64mm or 120mm end wall girts.

For 64mm end wall girts follow next step (Step 7.1) for 120mm end wall girts go to Step 7.2

7.1 Top hat 64mm end wall girt option

If you have 64mm end wall girts, there is no end wall mullion bracket supplied to attach the mullion to the rafter. Instead you just screw through the rafter into the mullion, or alternatively screw through the apex bracket into the mullion (as per drawing 7.1). No bracket is needed as the rafter and column flange thickness is the same thickness as end wall girts (64mm).

7.2 Top hat 120mm end wall girt option

If you have 120mm end wall girts, there is an angle bracket which is called an end wall mullion bracket which will attach the end wall mullion to the rafters. The bracket is needed as the 120mm top hat is larger than the flange size of the columns and rafters.

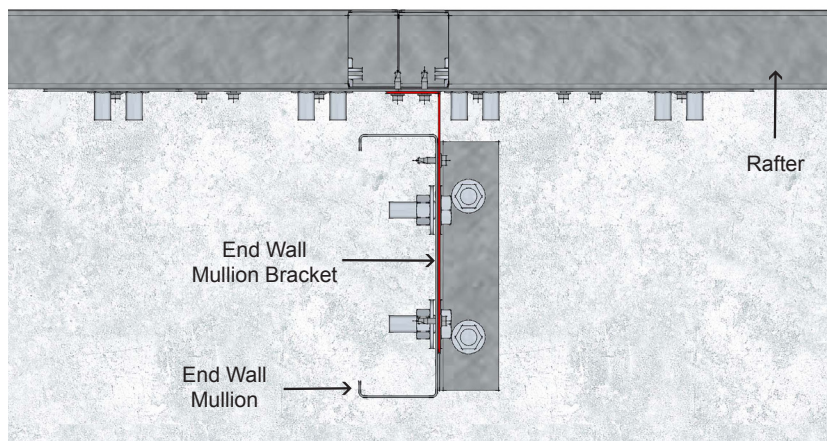
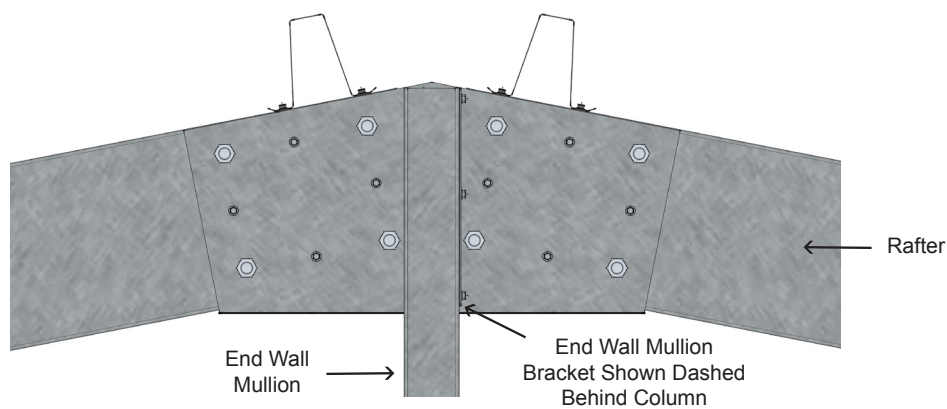

Note: It may be necessary to prop and rope the mullion to hold it plumb, and to ensure it has enough strength to brace all the rafters when in place.

STEP 9 Installing Remaining Rafters

Install all remaining rafters as in Step 7.

Be sure to brace all rafters before removing any lifting devices. A good way to do this is to run 2 rows of roof purlins (one each side of the roof up near the apex) back to the first rafter you installed that has mullions in place, and use ropes and props to hold everything steady. Ensure all rafters are parallel and plumb.

On large buildings where the frame size is greater than C150, it will be necessary to install all the purlins in the first bay and install the roof bracing to hold the heavier rafters in place.

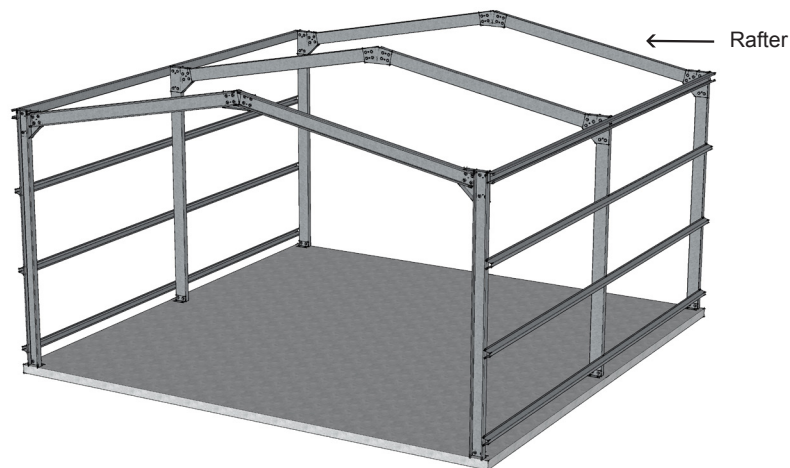

STEP 10 Fixing Roof Purlins

Lay out the roof purlins onto the rafters, using the temporary screws previously installed from step #2 that are in place from a previous step. First and last bay roof purlins should be installed flush with the outer face of the rafters on the end wall.

Fix into position with one screw per connection initially to hold purlins in place. Ensure that all end walls and all intermediate rafters are plumb before the roof purlins are fully fixed in place in accordance with the engineering plans.

Ensure that the spacing between the rafters is the same as the spacing between the columns. If roof bracing is required, fix into position as per the engineering plans prior to sheeting the roof.

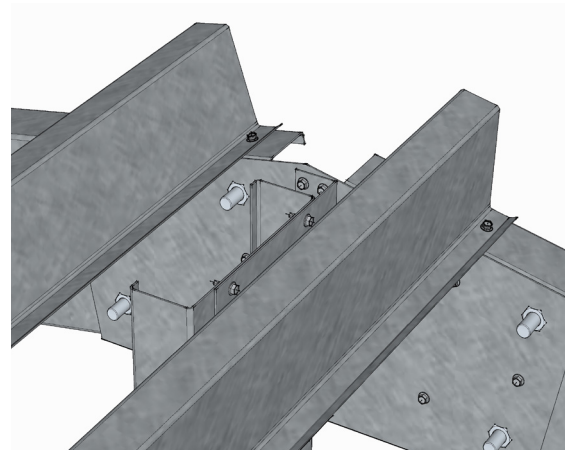
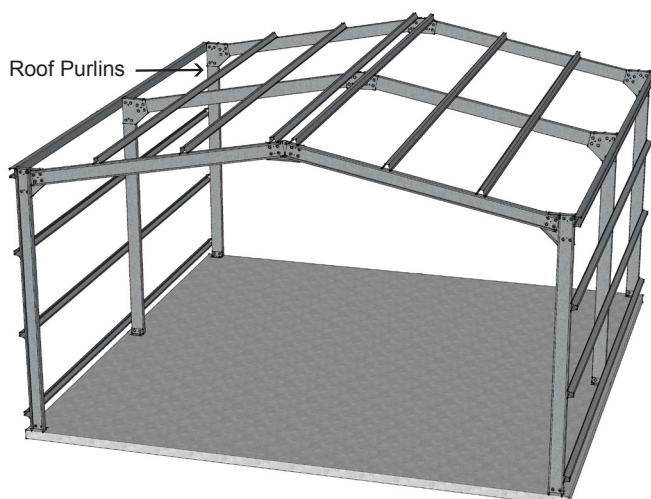

STEP 11 End Wall Roller/s Columns

Refer to your engineering plans for end wall roller door locations. If there are no end wall roller doors in your building then continue to step 13.

End roller doors are supplied with 'C Section' roller door columns to frame the opening, or alternatively are fixed on the existing end wall columns or rotated end wall mullions (to create greater opening widths) - refer to your engineering plans to determine what is applicable for your building. Detailed instructions for installing your roller door are supplied in the roller door bracket box.

The width of roller door frame openings will be narrower than the actual door (curtain) width by either 50mm or 100mm depending on door track size. Check your roller door instructions for correct opening size.

Mark out the position of roller door columns on to the concrete slab. Locate your roller door columns and bolt the base brackets as per engineer's drawings.

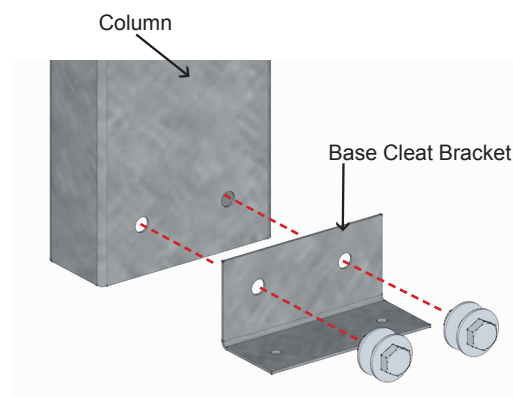

Stand roller door column/s in position and plumb column. Mark the top and bottom of the rafter onto the roller door column and notch the column as in drawing 10.1. Stand the roller door column back up in position, fix it to the concrete with masonry anchors. Now plumb the column and screw/bolt to rafter as per engineer's plans.

Tip: Spray all cuts with Cold Gal, to prevent any corrosion.

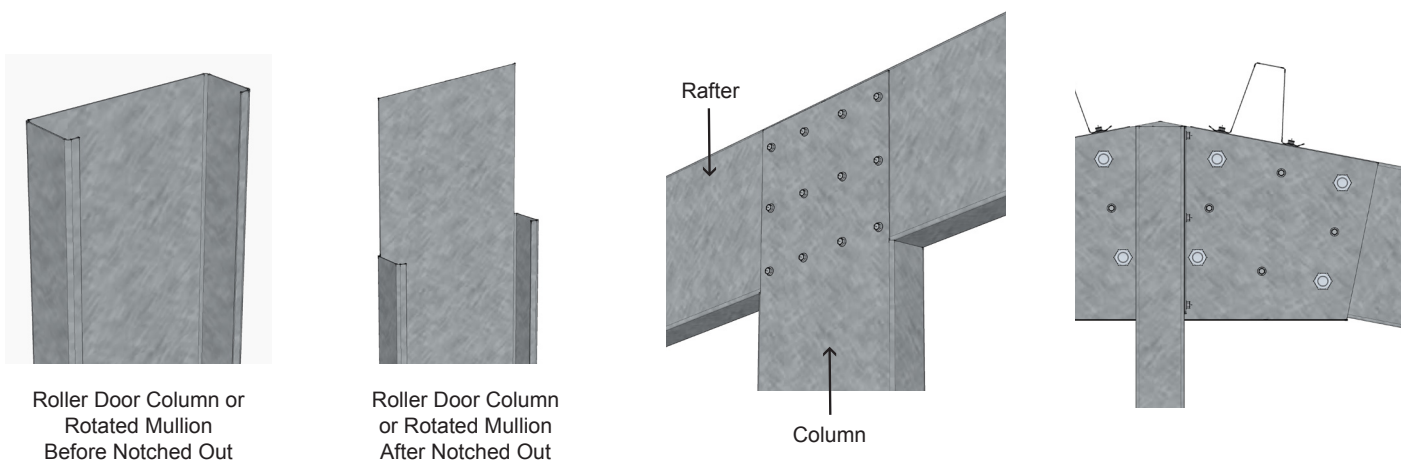

Drawing 10.1

STEP 12 End Wall Roller/s Header

Roller Door header installation heights are generally located on your engineering plans.

NOTE: Check the overall height of your roller door rolled up (usually 350mm – 600mm) and ensure that the door will fit in the space allowed above the header and below the roof sheeting. If not the header height will need to be lowered.

Apart from in the above situation where the roller door will conflict with the roof sheeting, the opening height of the roller door is generally the same as the height of the door subject to the building being (e.g. 2.5m high door will have a 2.5m clearance under the header beam).

Mark the opening height up both columns and attach end wall girt bracket (which you will attach the roller door header to). Screw header beam into place, ensuring the beam is level across the opening.

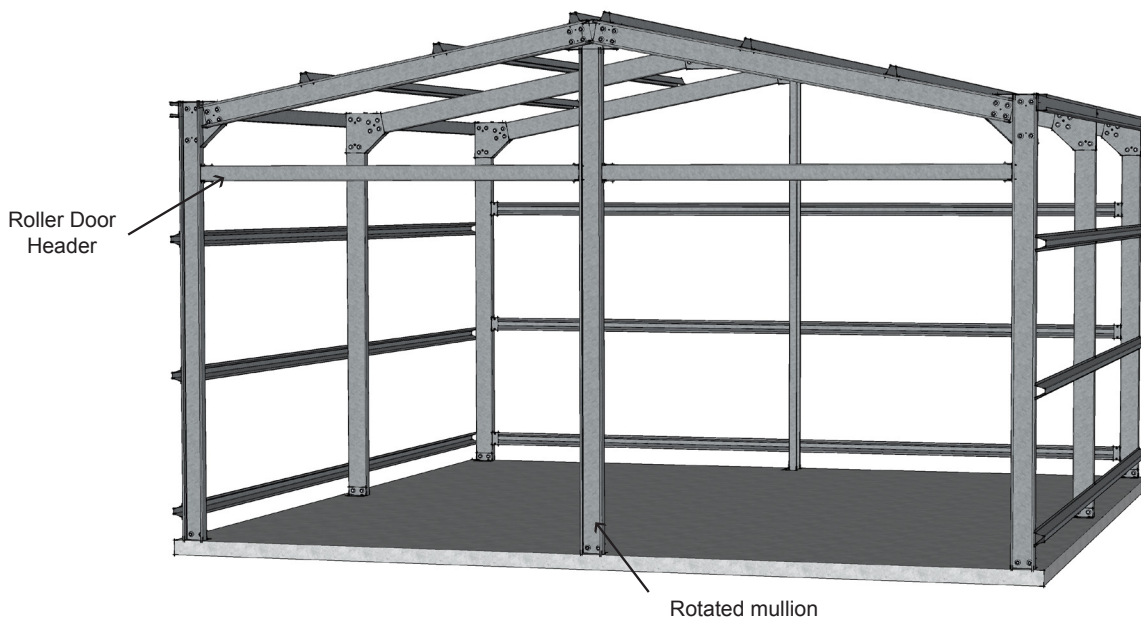
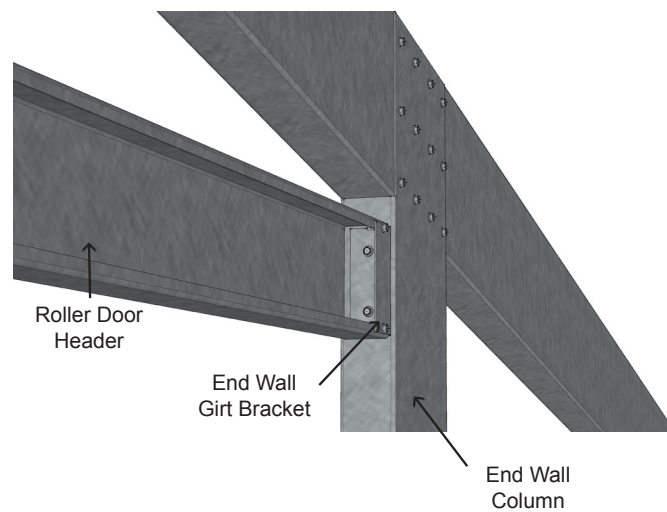

STEP 13 End Wall Girts

Install End Wall Girt brackets on the inside of End Wall Columns and Gable End Roller door Posts (only if you have end wall roller doors). End Wall Girts spacing as per engineer's plans.

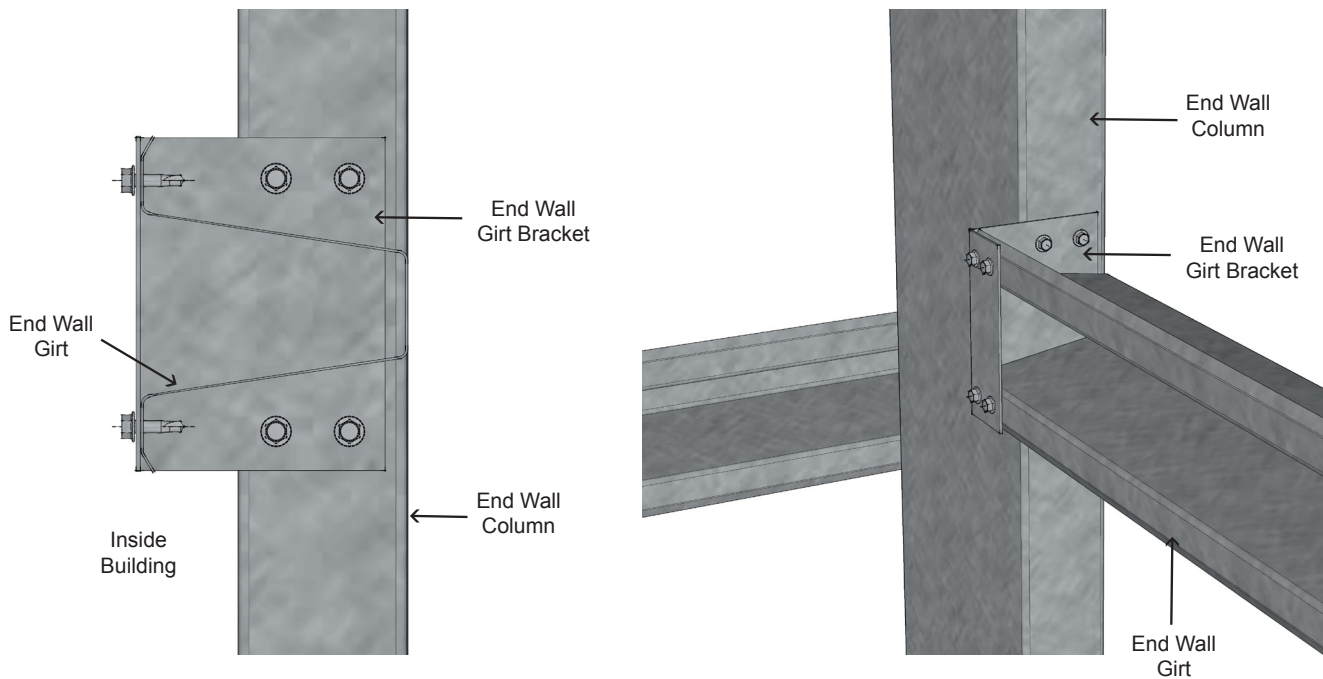

STEP 14 Fixing Knee & Apex Braces (if required)

Install knee and apex braces (if required) as per engineer's plans. Where required, Knee and Apex Braces are critical elements and must be installed as per engineering details.

This will require the flanges of the Knee and Apex Braces to be cut away where these contact the Columns and Rafters - as per below drawing. (Especially so for Back to Back frames.)

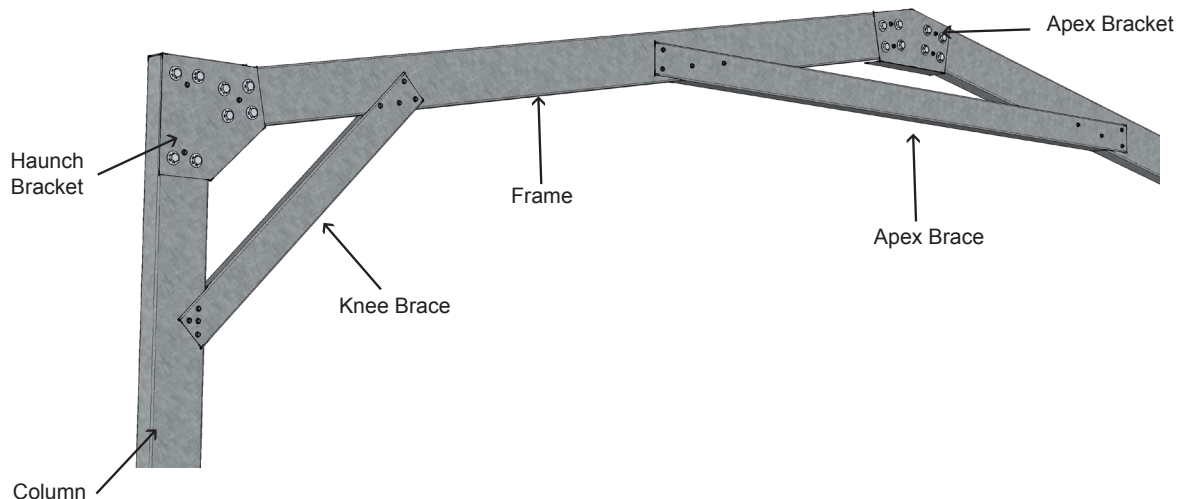

STEP 15 Fixing Fly Bracing (if required)

Please check and install fly bracing if required, as per your engineering plans.

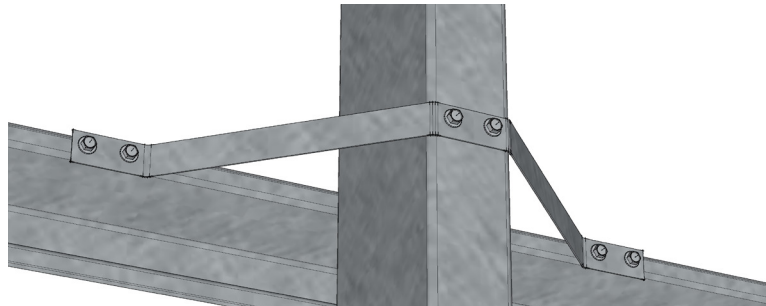

STEP 16 Side Wall Roller Doors (if required)

Refer to your engineering plans for side wall roller door locations. If there are no side wall roller doors in your building then continue to step 17.

Side roller doors are supplied with 'Z Section' roller door columns to frame the opening. Detailed instructions for installing your roller door are supplied in the roller door bracket box.

The width of roller door frame openings will be narrower than the actual door (curtain) width by either 50mm or 100mm depending on door track size. Check your roller door instructions for correct Opening size.

Mark out the position of roller door columns onto the concrete slab.

Plumb these lines up onto the wall girts that you have cut up and installed from the consolidated wall girts as shown above in section 6. and cut the wall girts plumb and true at this location.

Locate your roller door columns 'Z Section' and bolt the base brackets (to engineer's drawings).

Stand roller door column/s in position and plumb column. Mark the top and bottom of the eave purlin onto the roller door column and notch the 'Z section' column around the eave purlin.

Stand the roller door column back up in position, fix it to the concrete with masonry anchors.

Now plumb the column and screw/bolt to rafter as per engineer's plans.

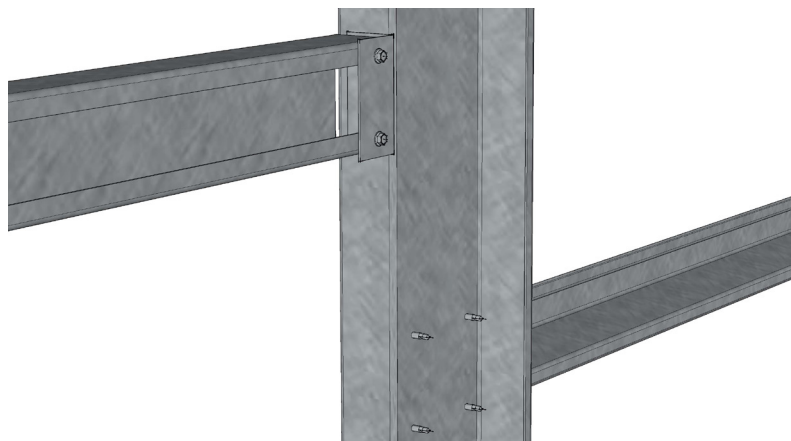

Tip: spray all cuts with Cold Gal, to prevent any corrosion

STEP 17 PA (Personal Access) Doors (if required)

All PA door jambs (to suit 64mm or 120mm wall girt) are supplied 2.7m long. On all buildings with an eave height 2.7m or less, the jamb will attach to the eave purlin. In all other cases it will attach to the next wall girt above the door head. Check plans for door location.

Measure the opening required for your door, and mark this onto the concrete slab. Plumb these marks up onto the wall girts, and cut the wall girts.

Locate your PA door jambs and screw on the base brackets (to engineer's drawings). Stand PA door jambs in position and plumb. Mark the top and bottom of the eave purlin (or wall girt) onto the PA door jambs and notch the jamb around the eave purlin (wall girt).

Stand the PA door jambs back up in position, fix it to the concrete with masonry anchors.

Now plumb the column and screw to eave purlin (wall girt) as per engineer's plans. Screw all wall girts to the jamb. Ensure girts remain level.

Tip: mark the opening 5-10mm larger than required opening to allow for inaccuracy when cutting wall girts.



STEP 18 Windows (if required)

Best Sheds windows are 2 corrugated sheets wide. (Note - The window does not need to be installed at sheeting overlap)

It's best to mark the approximate position of the window on the face of the wall girts. Then start wall sheeting and when you come to your marks, adjust them to suit the wall sheeting (the window needs to be installed starting at the lowest valley in the wall sheeting - Please call your sales representative if you have any questions before you cut sheeting)

Sit the window on the wall girt, with the bottom fin of the window running down the face of the wall girt. Now slide the window along so the side fin of the window goes behind the wall sheet already in place.

Screw the window to the wall girts, and place a screw through the wall sheeting into the top fin of the window.

Now measure and cut sheets above and below the window and screw them into place. Continue wall sheeting.

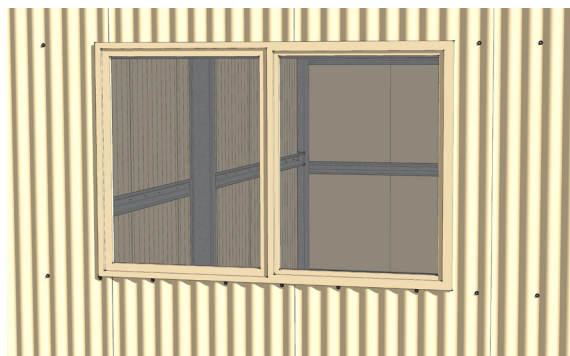

*For more information on PA door & Window installation please visit www.bestsheds.com.au

STEP 19 Side Wall Sheeting

Locate the side wall sheeting, sheets will be approximately 20mm longer than column length (this allows the sheets to overlap the concrete slab).

Top of side wall sheets will be flush with top of Eave Purlins.

Ensure you have counted the wall sheets provided & lap the sheeting accordingly as your shed may only require half a sheet to be utilised on both sides of the walls to minimise wastage of steel.

Check to see if insulation is supplied for your walls. If so cut insulation to length and install as you are installing the wall sheets.

If there are any openings in the side walls, cut sheets as required to match frame opening already installed.

Check each sheet is plumb before screwing off.

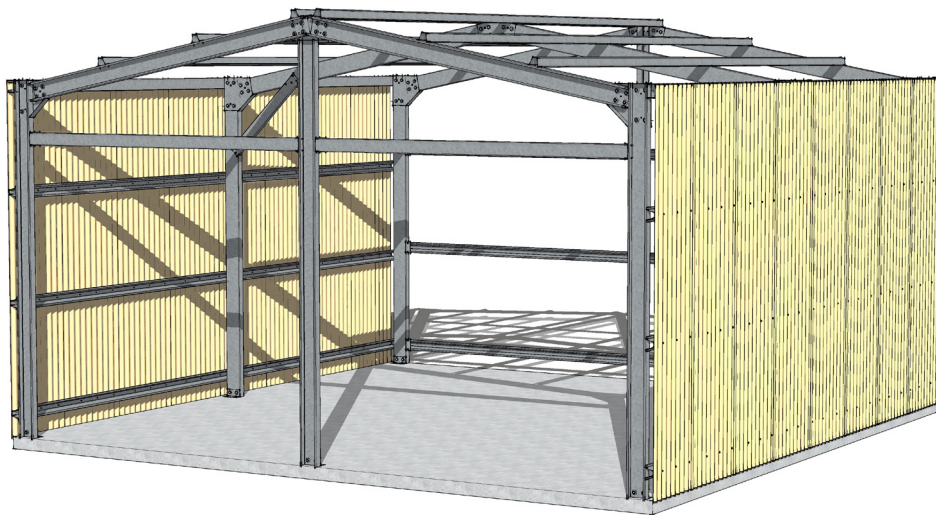

Screws as per wall sheeting profile

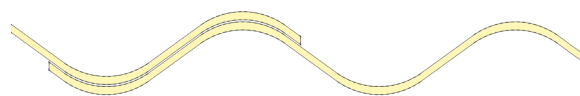

Overlap Detail

STEP 20 End Wall Sheeting

Locate the end wall sheeting. End wall sheets are all one length (longest length required), and will need to be cut to the rake of the roof onsite. (Image below shows approximate lengths that the sheeting will initially need to be cut down to, then cut the rake once square sheets are installed).

Sheets will overlap slab same length as side wall sheeting and the top of end wall sheets are to be cut to underside of roof sheeting.

Ensure you have counted the wall sheets provided & lap the sheeting accordingly as your shed may only require half a sheet to be utilised on both sides of the walls to minimise wastage of steel.

If there are any openings in the end walls, cut sheets as required to match frame opening already installed.

Check each sheet is plumb before screwing off.

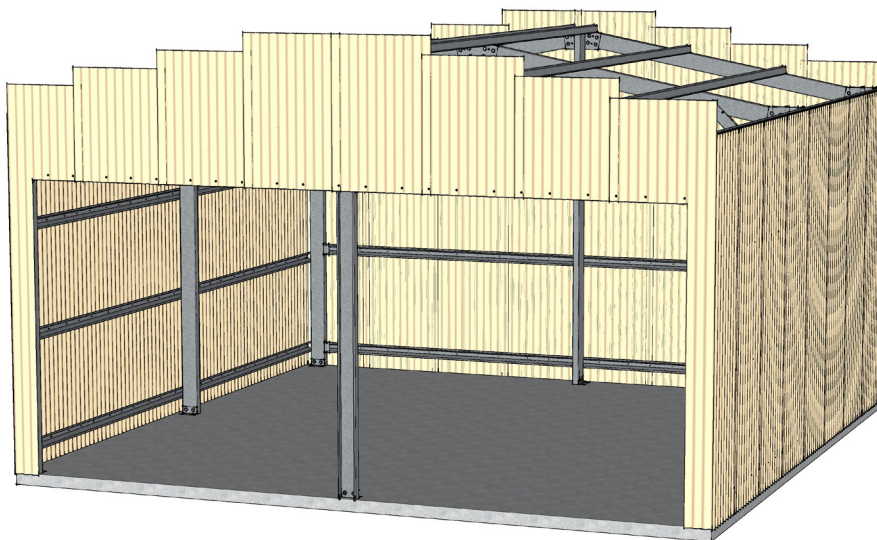
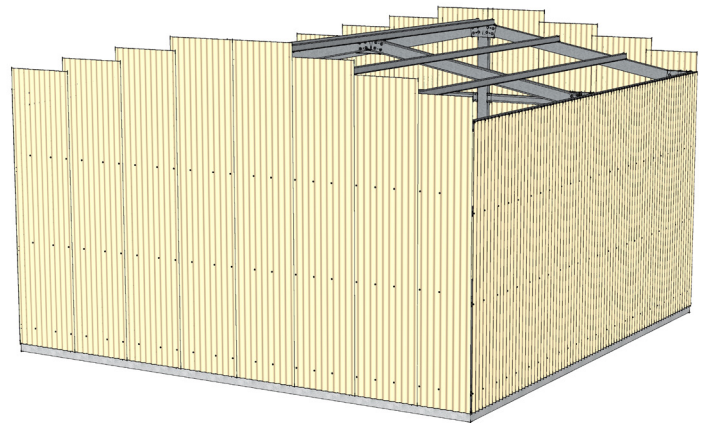
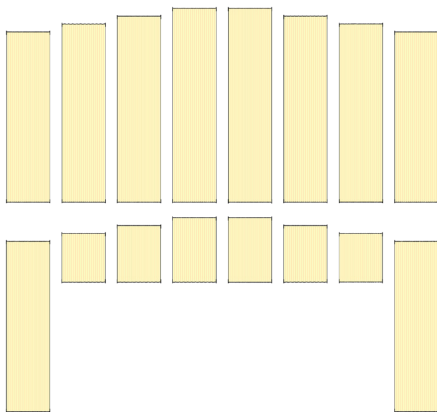

STEP 21 Gutters

Work out how many and the location of your downpipes. Number of downpipes is provided on your material list.

Cut the downpipe nozzles out of the gutters (to suit above) and install nozzle. Ensure you place silicone on all rivets, and where the nozzle meets the gutter.

Install stop ends on the appropriate gutters. Again, ensure you use plenty of silicone, and make sure you strip the protective plastic back off the guttering and stop ends.

Now need to mark the fall of the gutters with a chalk line onto the wall sheeting, one end (high end) starting at the top of wall sheeting, and the other end where the downpipe is (low end) having a minimum fall of 1:500.

E.g. A 7.0m long gutter must drop 1mm every 500mm, $7000\text{mm} / 500 = 14$ Building minimum fall = 14mm

Gutter brackets are now to be installed to the wall sheeting at maximum 1.2m spacing's. Rivet gutter brackets to the ridge of the wall sheeting, aligned with the chalk line indicating the required fall.

Hook the gutter onto the end of the gutter bracket and rotate into place. Ensure you place silicone on all gutter joins, and lap the gutters in the direction of the fall of the roof.

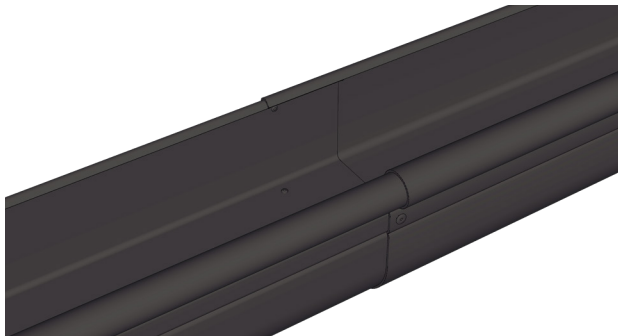

Guttering Overlap

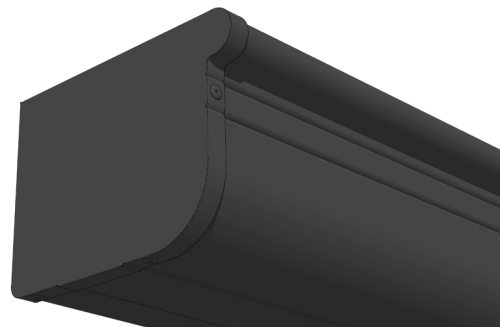

Gutter End

STEP 22 Roofing Sheeting

Check engineer's plans for any strap bracing required in the roof frame and ensure all bracing is installed as per plans.

Screw all sheeting off to engineer's plans.

Check to see if insulation is supplied under your roof sheets. If so cut insulation to length and install as you are laying the roof sheets.

Turn up ends of sheets 60 degrees (each valley of the sheet) at the ridge line.

Ensure you have counted the roof sheets provided & lap the sheeting accordingly as your shed may only require half a sheet to be utilised on both sides of the roof to minimise wastage of steel.

Roof sheeting will overhang wall sheets approx. 50mm into the gutter.

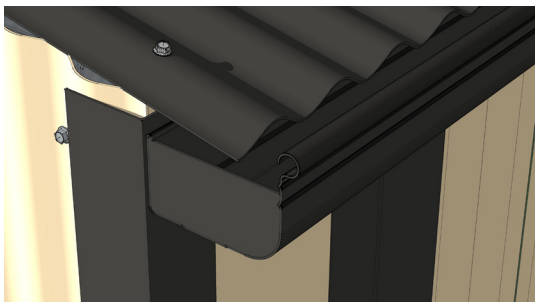
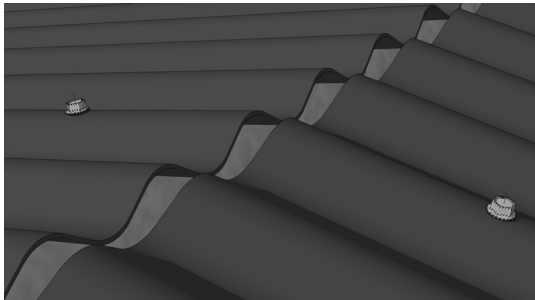
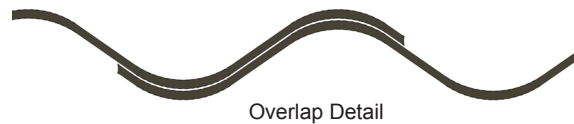

Overhang gutter by approx. 50mm

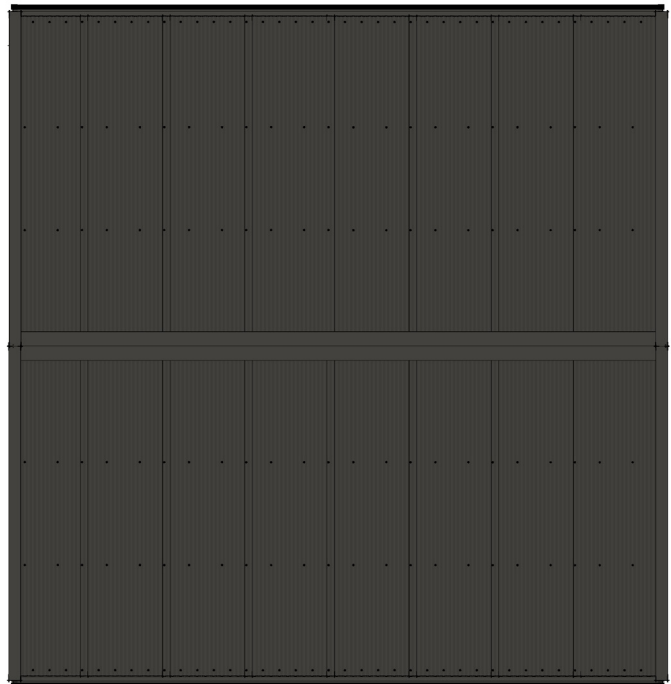

Roof sheets in place

STEP 23 Flashings

BARGE FLASHING

Peel the protective plastic coating from one barge, lift the barge into place (either side) and align top of the barge with the apex (middle) of the building. Screw through the top leg of the barge into roof purlins. Ensure the barge flashing is tight into the gable end wall sheeting, and that the barge face is plumb (i.e. not leaning over at the top).

Peel the plastic off the second barge and cut a 'plumb cut' on the apex end (plumb cut will be roof pitch). Lift the barge up into position, overlap this second barge over the first barge - using silicon to seal in gaps in the top leg of the barge. Screw barge into place.

Now put either coloured rivets or wall screws (10-16x16) through the vertical leg of the barge every 4th rib of the wall sheeting.

Plumb cut the ends of the 2 barges flush with the end of the gutters. Now repeat this step for the other end of the building.

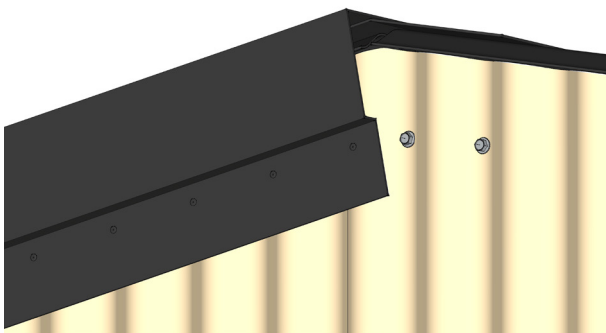

First side installed

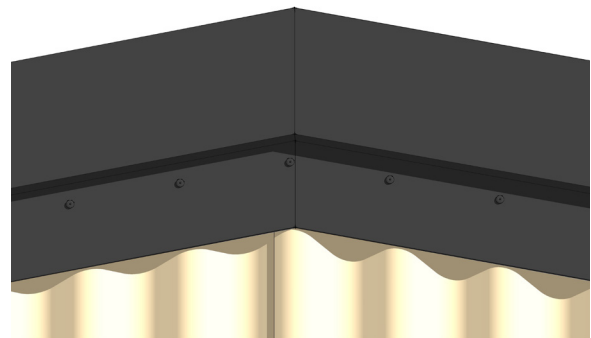

Barge Capping Complete

BARGE FLASHING ON A TH120 SHED WITH AN OPEN BAY GABLE END WALL (UNSHEETED)

As above but this time you will need to install TH120 end wall girt brackets onto the roof purlin, so you have material to fix the front face of the barge capping off too. See picture below.



RIDGE FLASHING

Ensure ridge capping is flush with the face of the barges.

A good tip is to trim the ends of the ridge (where they run to the gable ends) to a taper for aesthetics when looking up at the ridge from the ground.

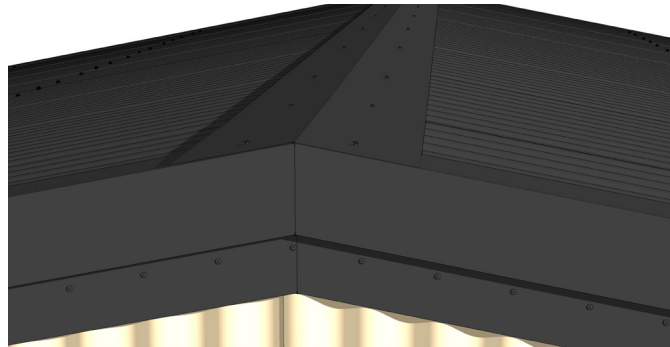

CORNER FLASHING

Locate corner flashings, peel off protective plastic and install them to the corners of the building using either coloured rivet or walls screw (10-16x16).

Ensure corner flashings are watertight and will not rattle in the wind. Generally, there should be a maximum of 2 fixings every 1.0m down the length of the flashing (one fixing each side of the flashing).



OPENING FLASHINGS

Opening flashing same as corner flashings. Only difference being you will have to notch the flashings to step over the slab. And in the case of headers, each end will need to be notched to suit side opening flashings.



Note: Gutter side roller doors on a TH120 shed are supplied with double the opening jamb flashings to span the space between the wall sheeting and the Z250 opening jamb. As shown below

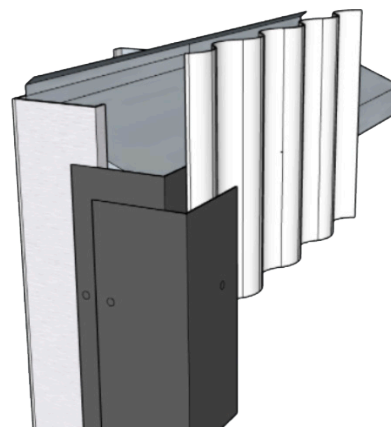

STEP 24 Downpipes

Locate downpipes and peel off plastic protective coating. Fix the downpipes to the nozzles with 4 x rivets or wall screws (10-16x16) per downpipe.

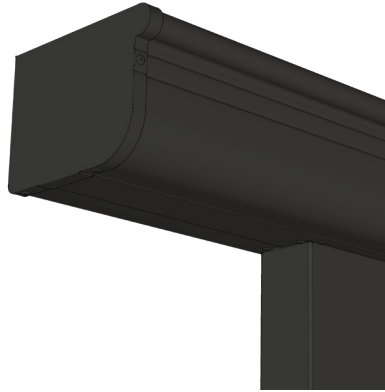

Fix the bottom of the downpipe with a roof screw from inside the building, through the bottom wall girt into the downpipe.

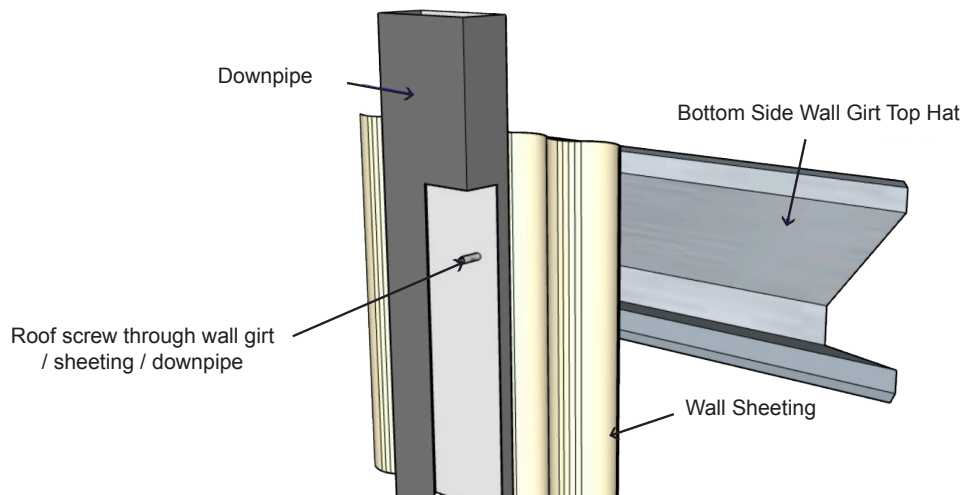

BUILD COMPLETE

Time to do a once over of the building, check that all bolts have been tightened and bracing is installed.

Sweep off the roof, and wipe over all walls to remove any swarf from cutting or drilling during the build process.

Sweep off the slab and remove all rubbish. Make sure you get every last screw off the slab or driveway before bringing any vehicles into the building.

Congratulations, you are now all done. Time to enjoy your new building, and send Best Sheds a completed photo to sales@bestsheds.com.au.

